

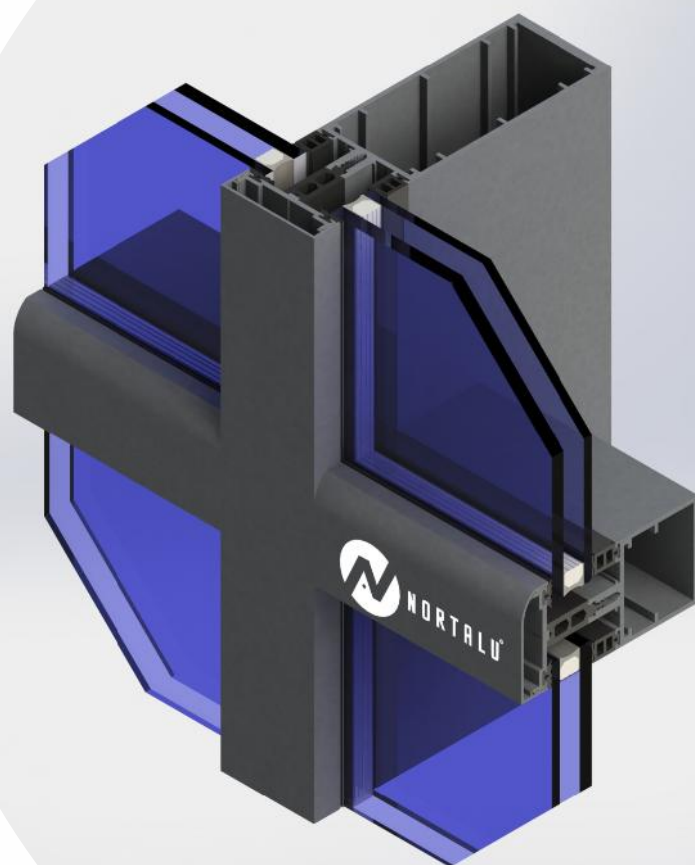

www.nortalu.pt

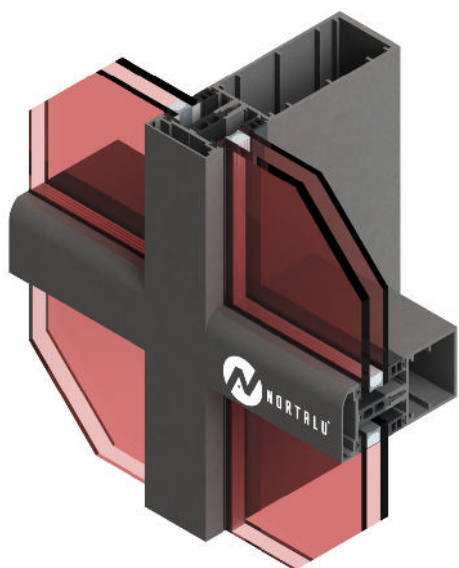

SÉRIE FC



SÉRIE FC

SISTEMA FACHADA

O sistema de fachada possui um conjunto completo de opções construtivas habitualmente utilizadas no revestimento de edifícios. As fachadas são um sistema de alumínio e vidro, melhor integrado com os novos conceitos de arquitectura para edifícios. Foi concebida de acordo com as mais rígidas especificações de qualidade, para garantir uma perfeita estanquidade à água e um completo isolamento térmico e acústico, aliado a uma perfeita harmonia estética.

Resultados do Ensaio do Tipo Inicial:

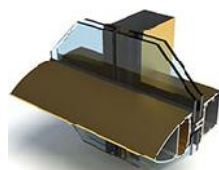
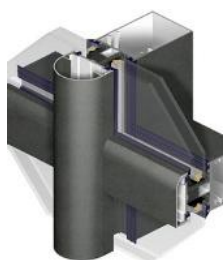

| Fachada Estrutural Fachada Horizonte | Com 1 vão Projectante e 1 Vão Oscilo-batente | Vão fixo |
|---|---|----------------|
| Permeabilidade ao Ar | Classe A3 | Classe A4 |
| Estanquidade à Água | Classe RE 1050 | Classe RE 1050 |
| Resistência ao Vento | Apto (1500Pa) | Apto (1500Pa) |
| Coef. Transm. Térmica | $U_w = 1,43 \text{ W/m}^2\text{K}$ | |

Soluções Construtivas:

- Versão Estrutural
- Versão Semi-Oculta
- Versão Oculta
- Versão Horizonte
- Versão DEC

Capacidade de Vidro:

- Versão Cortina
 - Vidro 12 a 47mm
- Versão Semi-Oculta (VEP)
 - Vidro 6 a 43mm
- Versão Oculta (VEC)
 - Vidro 6 a 43mm
- Versão Horizonte
 - Vidro 12 a 47mm
- Versão DEC
 - Vidro EXT 8 - 10 mm
 - Espaçador de vidro 16mm
 - Vidro INT 6 - 8 - 10mm

Vedantes:

- Material em EPDM ou PVC em conformidade com a norma aplicável.

Acessórios:

- Materiais em alumínio, zamac, aço inox e nylon em conformidade com a norma aplicável.



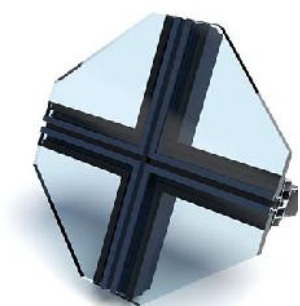

| Fachada Semi-Ocultas | Com 1 vão Projectante | Vão fixo |
|-----------------------------|------------------------------------|-------------------------|
| Permeabilidade ao Ar | Classe AE750 (Especial) | Classe AE750 (Especial) |
| Estanquidade à Água | Classe RE 1050 | Classe RE 1050 |
| Resistência ao Vento | Apto (1500Pa) | Apto (1500Pa) |
| Coef. Transm. Térmica | $U_w = 1,45 \text{ W/m}^2\text{K}$ | |

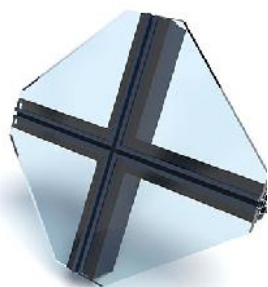

| Fachada Oculta | Com 1 vão Projectante | Vão fixo |
|-----------------------|------------------------------------|-------------------------|
| Permeabilidade ao Ar | Classe AE750 (Especial) | Classe AE750 (Especial) |
| Estanquidade à Água | Classe RE 1050 | Classe RE 1050 |
| Resistência ao Vento | Apto (1500Pa) | Apto (1500Pa) |
| Coef. Transm. Térmica | $U_w = 1,43 \text{ W/m}^2\text{K}$ | |

| | Resistência às Cargas Vivas Horizontais | Resistência ao Impacto | Resistência ao Peso Próprio |
|-----------------------------|--|-------------------------------|-------------------------------------|
| Fachada Estrutural | Apto (1500Pa) | Classe I5 | 1.08 KN Flecha Máxima 3mm |
| Fachada Semi-Ocultas | Apto (1500Pa) | Classe I5 | 1.08 KN Flecha Máxima 3mm |
| Fachada Oculta | Apto (1500Pa) | Classe I5 | 1.08 KN Flecha Máxima 3mm |

Nota: Dimensão das Fachadas ensaiadas com 5110*6250mm

FC.02 *Montante / Travessa*

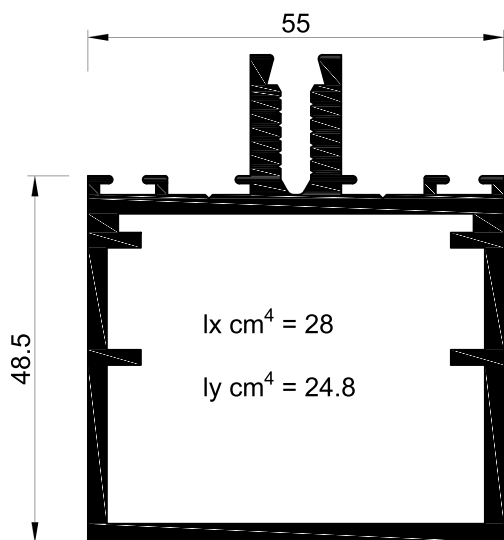

FC.00 *Montante / Travessa*

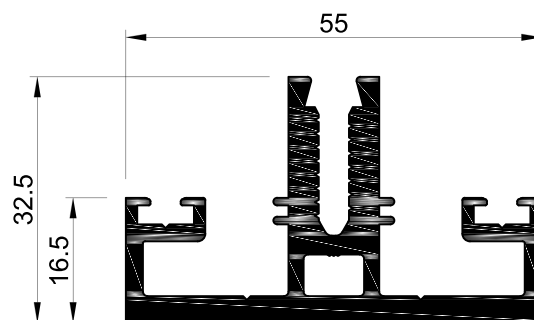

FC.24 *Montante / Travessa*

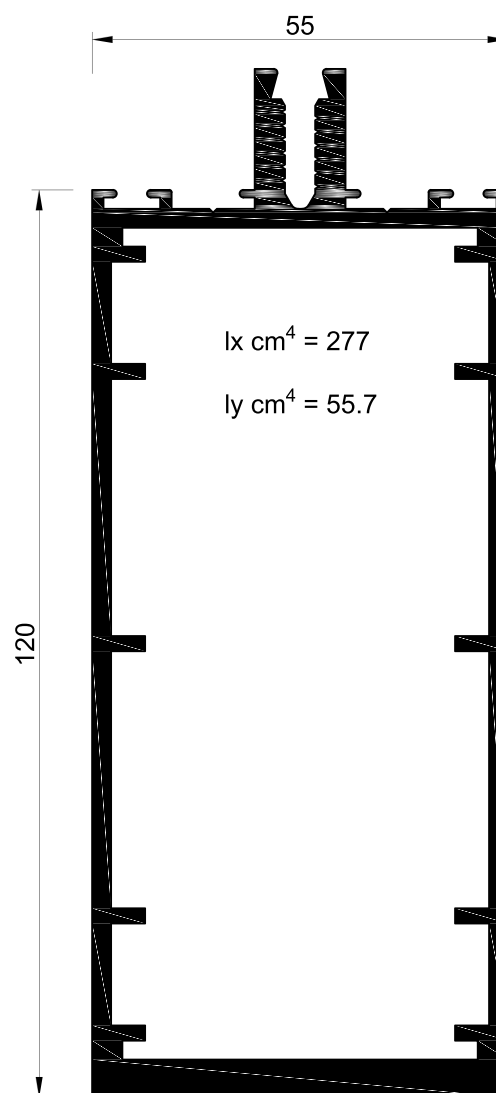

FC.01 *Montante / Travessa*

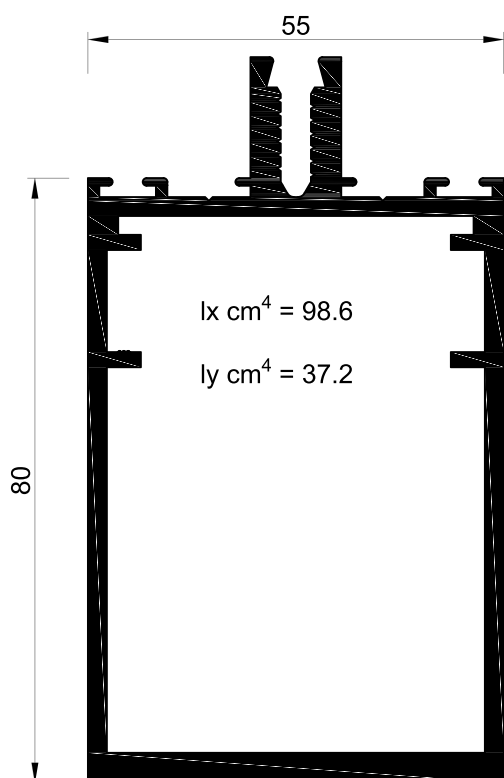

FC.34 *Montante / Travessa*

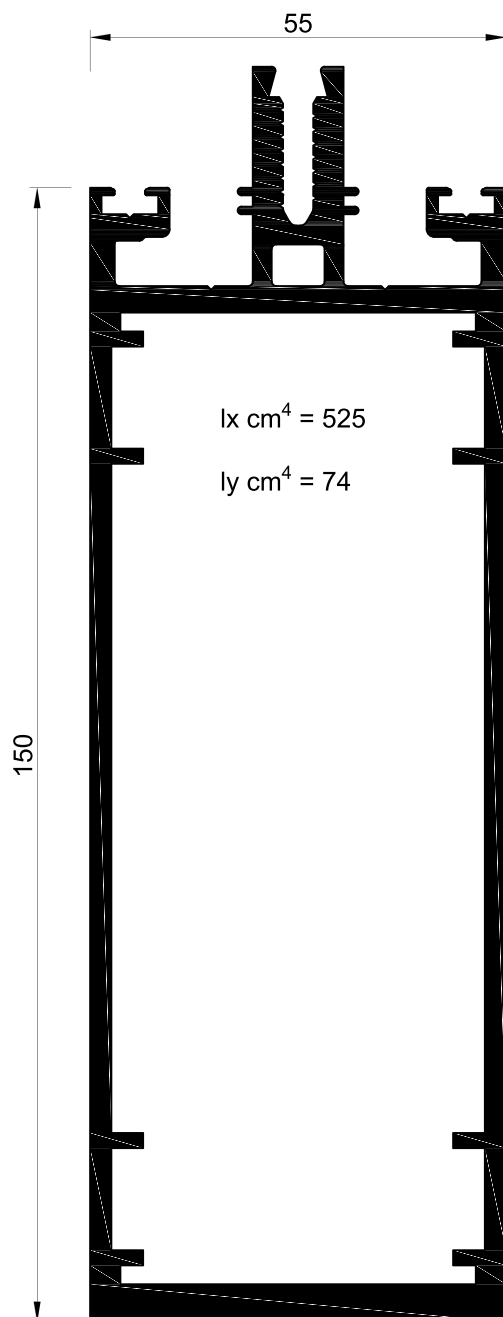

FC.47 *Montante / Travessa*

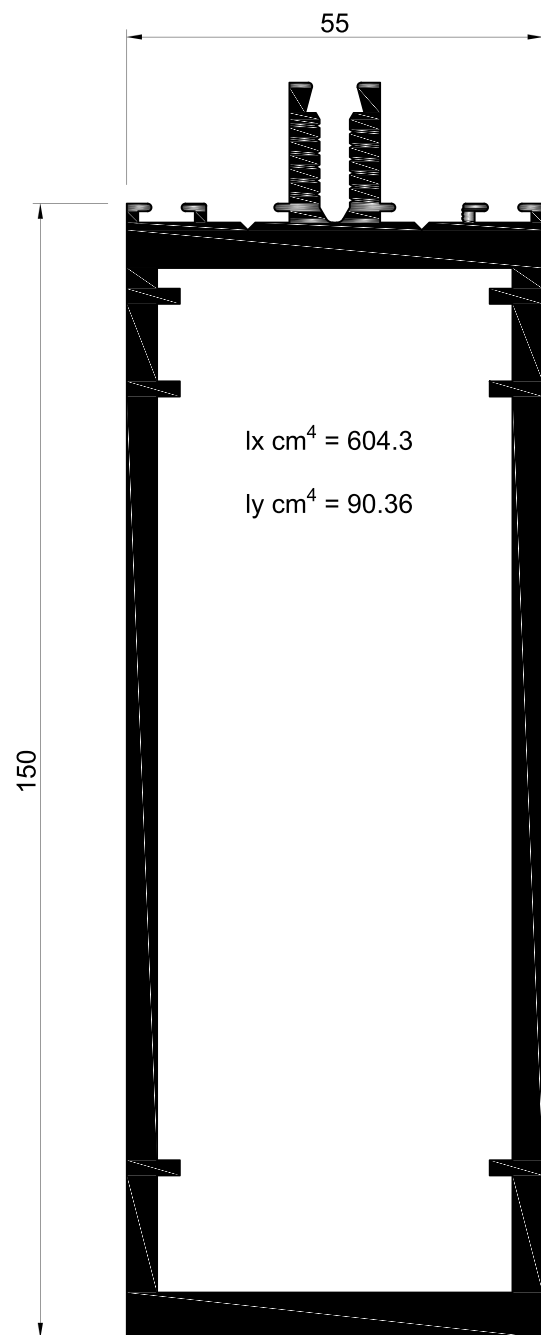

FC.40 *Montante / Travessa*

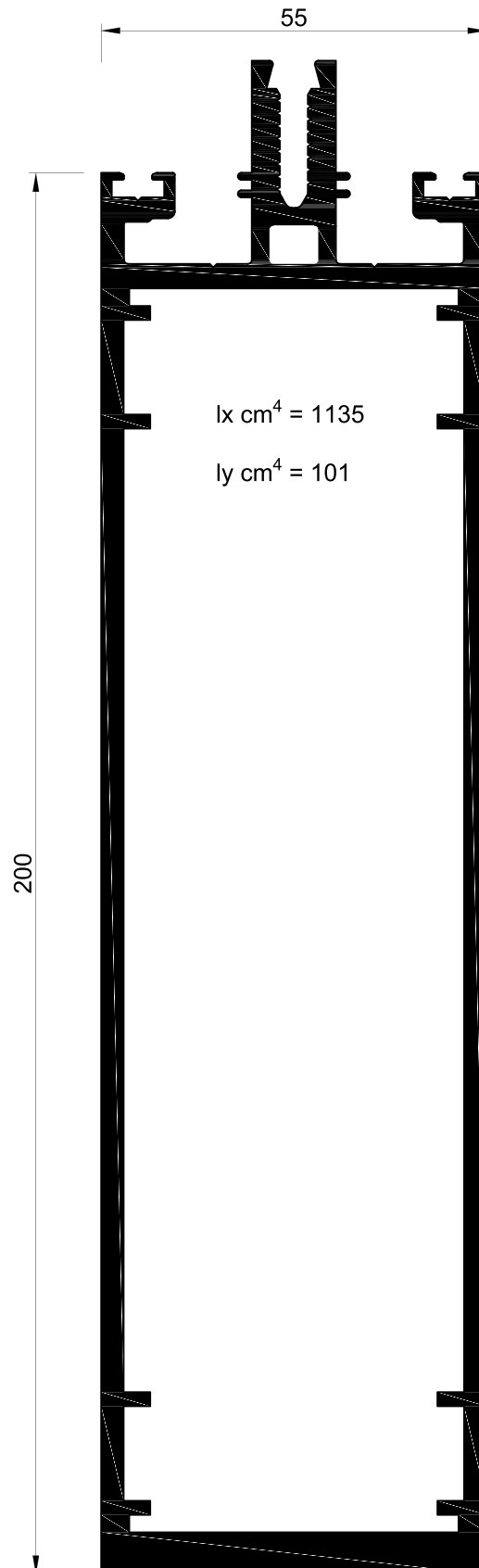

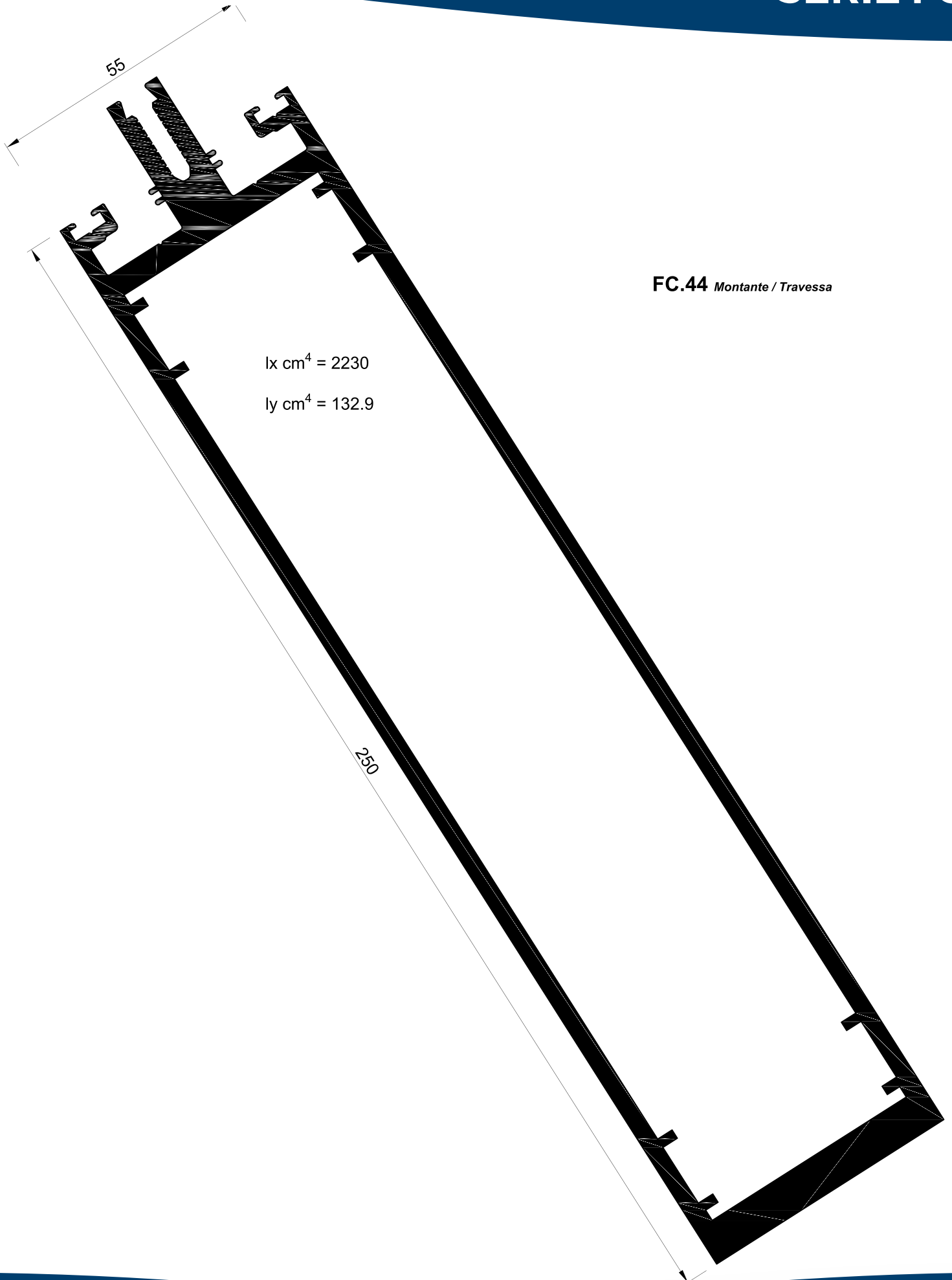

FC.44 *Montante / Travessa*

$$I_x \text{ cm}^4 = 2230$$

$$I_y \text{ cm}^4 = 132.9$$

FC.82 Montante / Travessa
(Para aplicação na solução Semi-Oculta e Oculta)

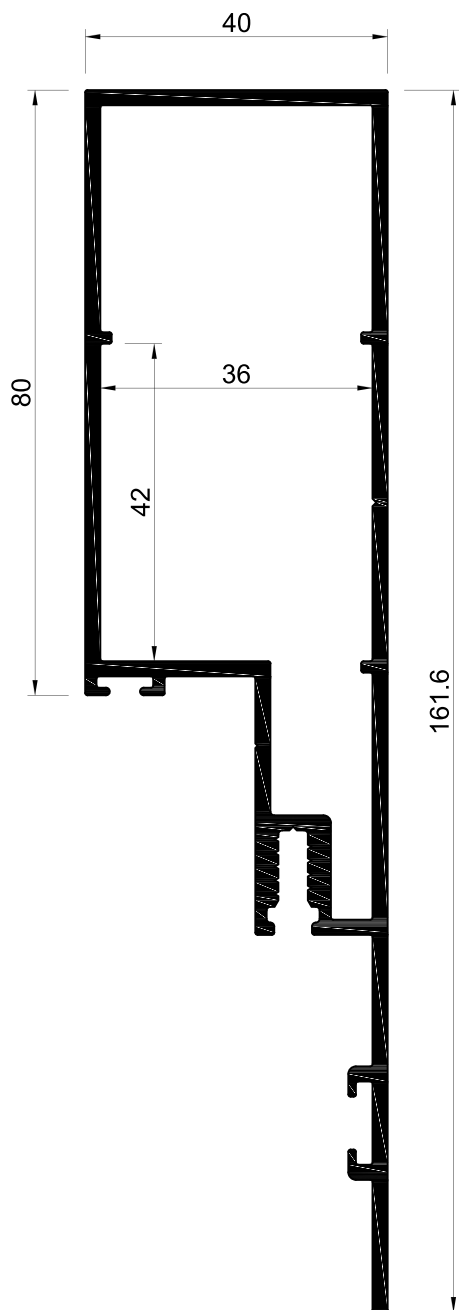

FC.83 Montante / Travessa
(Para aplicação na solução Semi-Oculta e Oculta)

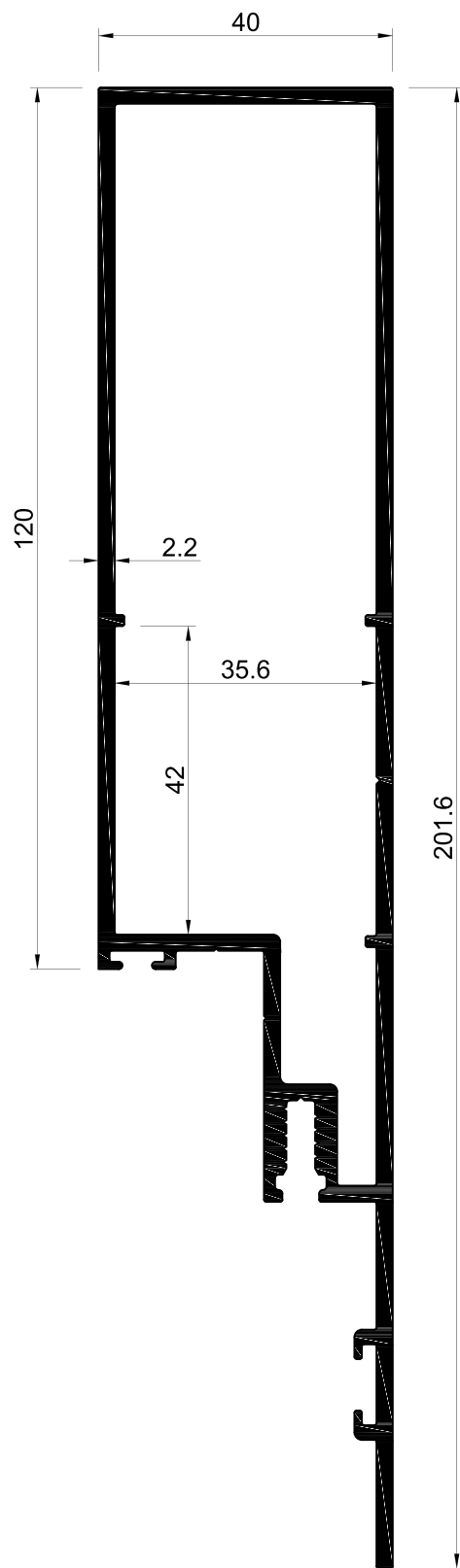

FC.09 Bite Para Montante / Travessa
(Aplicação para perfis dilatação)

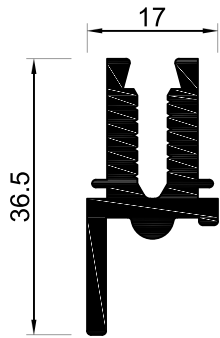

B.33 Barra Maciça

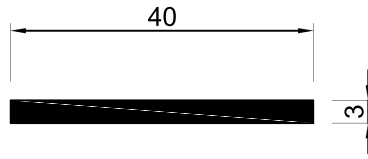

B.32 Barra Maciça

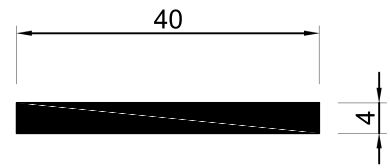

P.02 Tubo 30*15

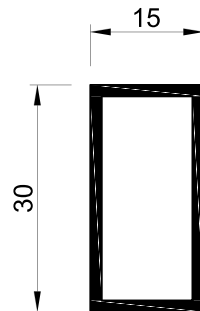

FC.08 Montante / Travessa Perfil Dilatação

$$I_x \text{ cm}^4 = 104.18$$

$$I_y \text{ cm}^4 = 4.99$$

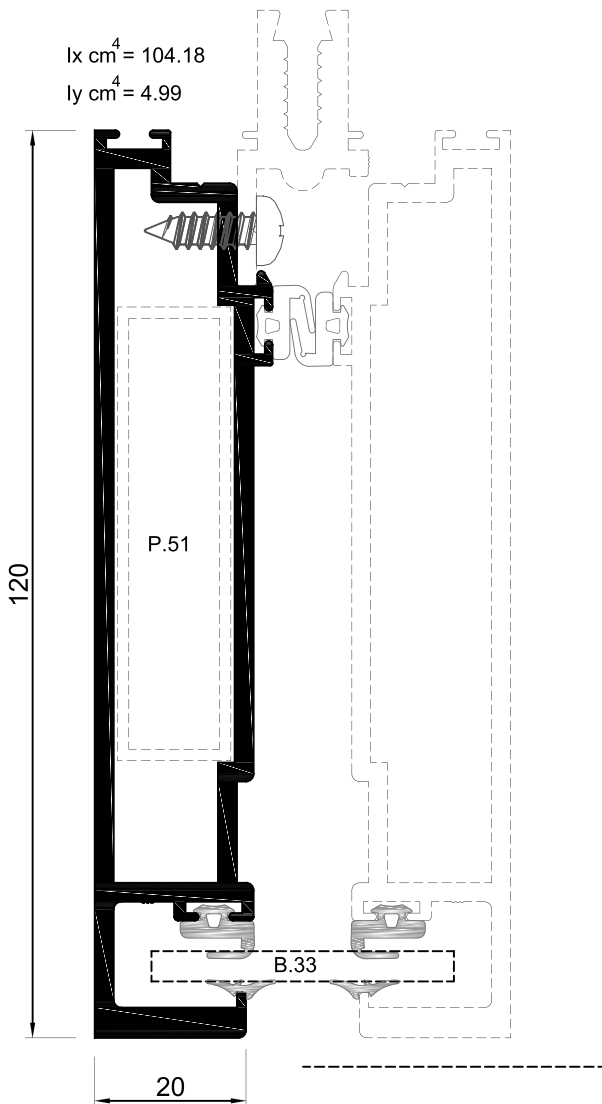

FC.28 Montante / Travessa Perfil Dilatação

$$I_x \text{ cm}^4 = 64.10$$

$$I_y \text{ cm}^4 = 4.48$$

P.51 Tubo 60*15

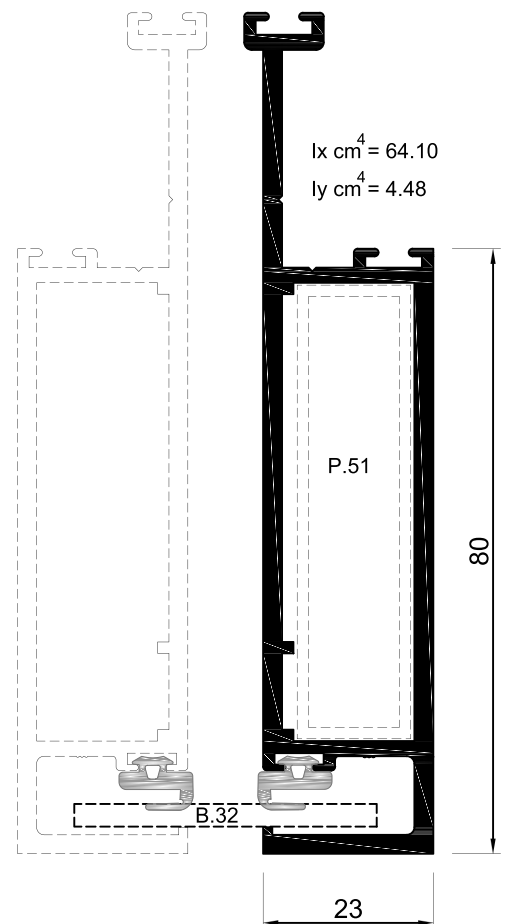
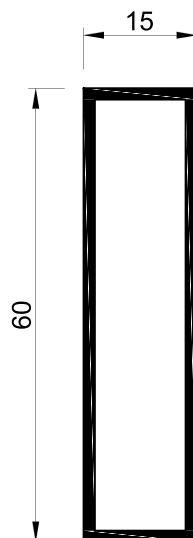

PERFIL FC 08 PARA JUNTA DE DILATAÇÃO, REMATE LATERAL OU ÂNGULOS EM FC SEMI-OCULTA OU OCULTA APLICAR UNICAMENTE COM O MONTANTE FC 24

PERFIL FC 28 PARA JUNTA DE DILATAÇÃO, REMATE LATERAL OU ÂNGULOS EM FC SEMI-OCULTA OU OCULTA

FC.42 Perfil Ângular 90°

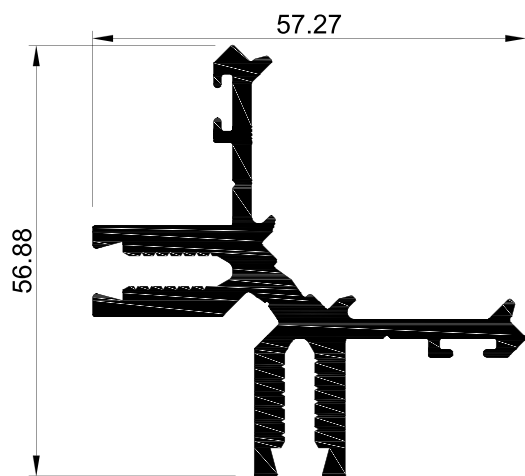

FC.30 Bite Para Montante / Travessa
(Aplicação Folha Semi-Oculta e Oculta)

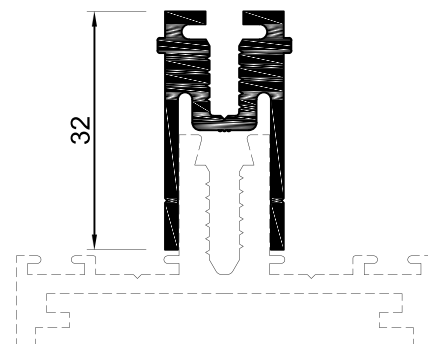

FC.12 Bite Para Montante / Travessa
(Aplicação Fachada Cortina)

FC.26 Bite Para Montante / Travessa Ângular
(Aplicação Folha Semi-Oculta e Oculta)

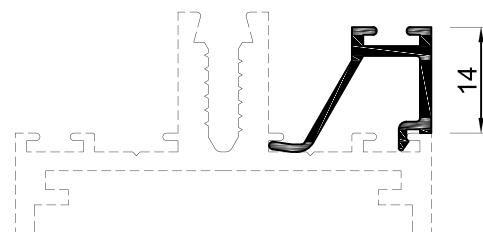
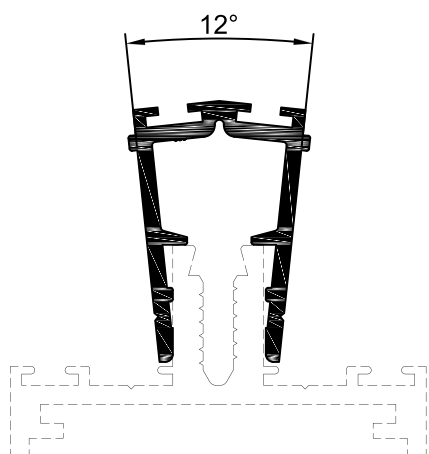

FC.04 Capa Interior Para Montantes / Travessas

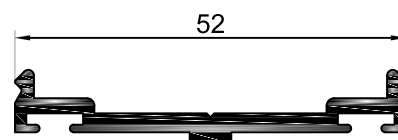

FC.05 Capa Exterior Para Montantes

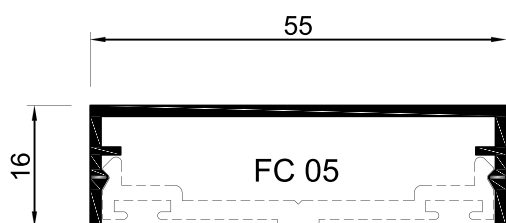

FC.06 Capa Exterior Para Montantes

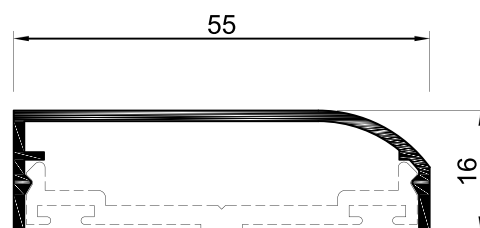

FC.39 *Capa Exterior*
(Versão Trama Horizontal)

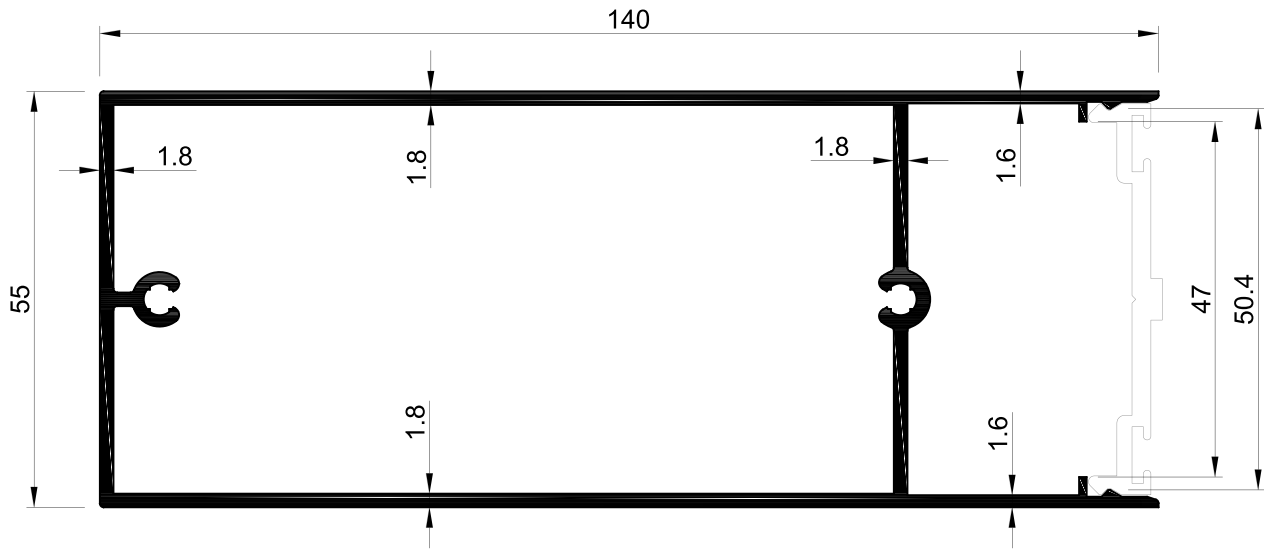

FC.22 *Capa Exterior*
(Versão Trama Horizontal)

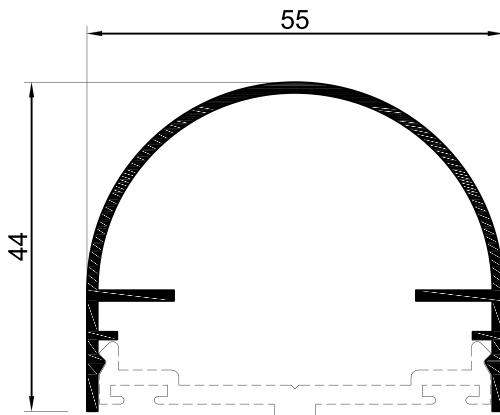

FC.25 *Capa Exterior*
(Versão Trama Horizontal)

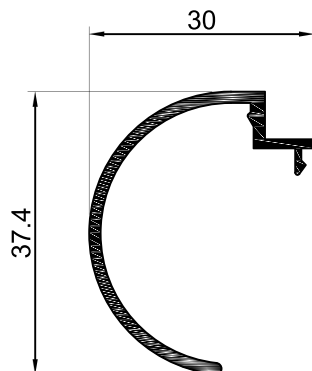
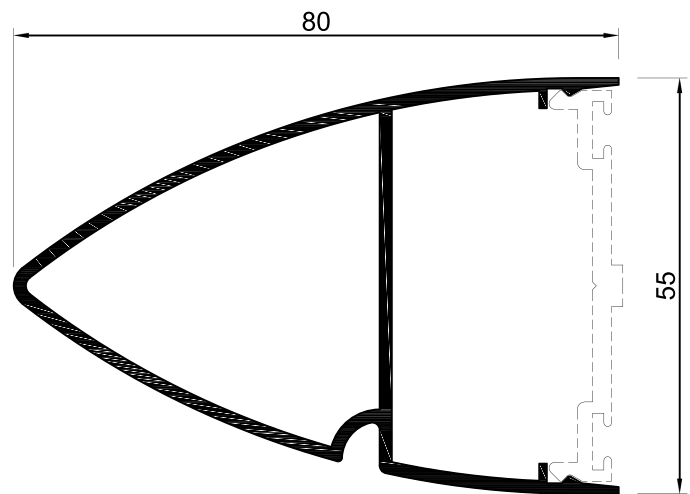

FC.11 *Capa Exterior*

FC.54 Aro Móvel Folha Oculta

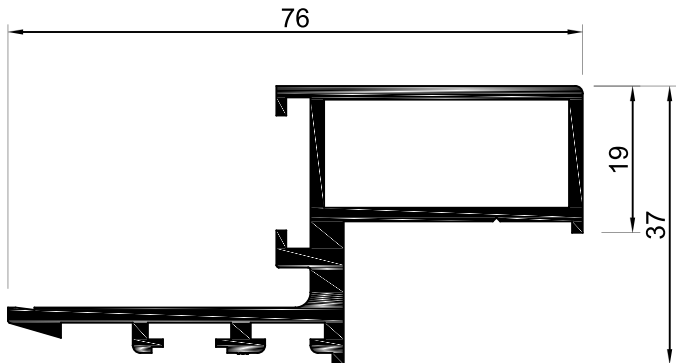

FC.15 Aro Móvel Folha Semi-Oculta

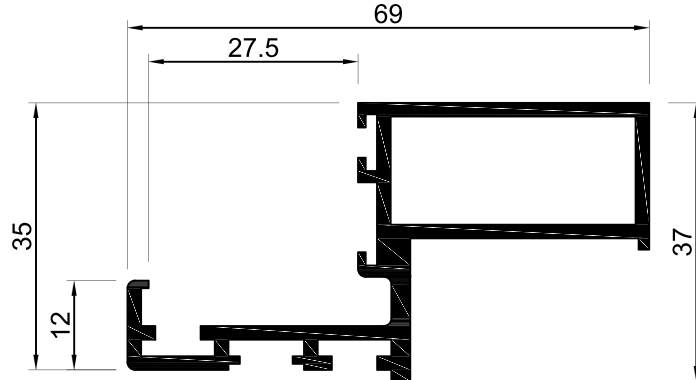

FC.14 Aro Móvel Folha Oculta

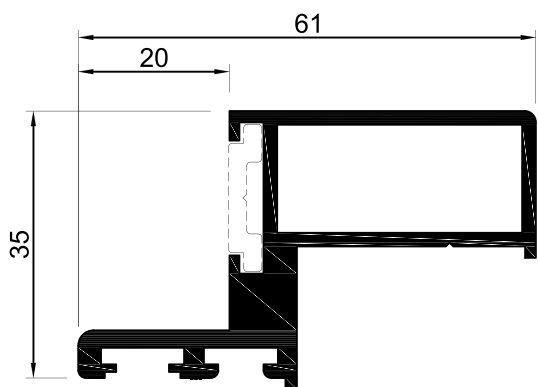

FC.45 Aro Móvel Folha Semi-Oculta

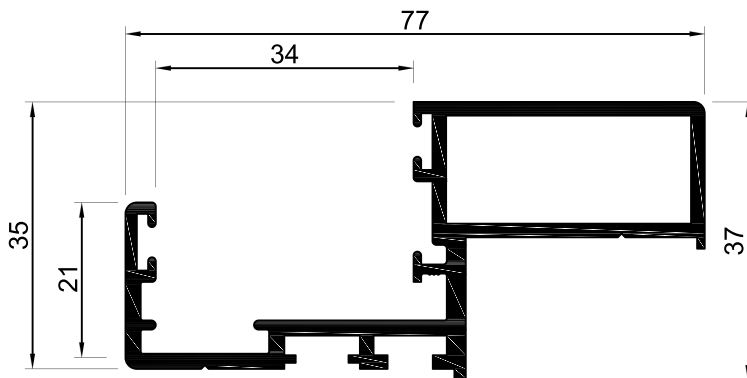

FC.23 Aro Móvel Folha Oculta (Vidro Simples)

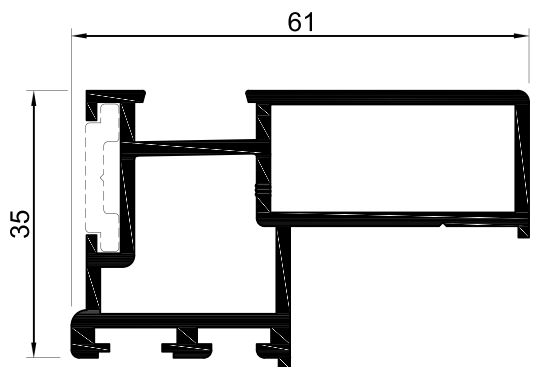

FC.35 Aro Móvel Folha Semi-Oculta (Vidro Simples)

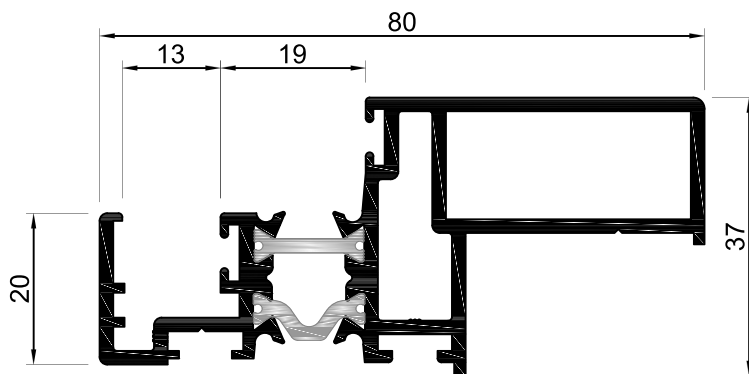

FC.64 Aro Móvel Folha Oculta

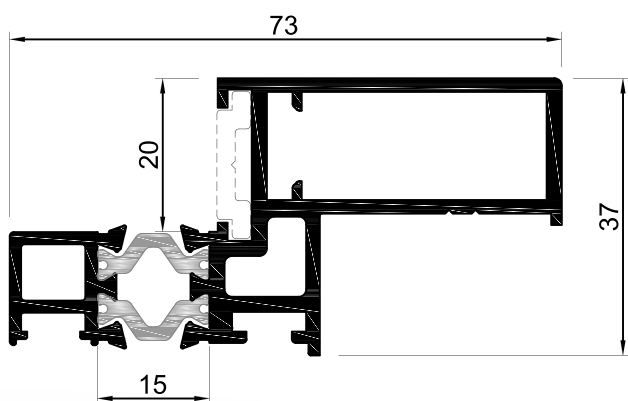

FC.35 Aro Móvel Folha Semi-Oculta

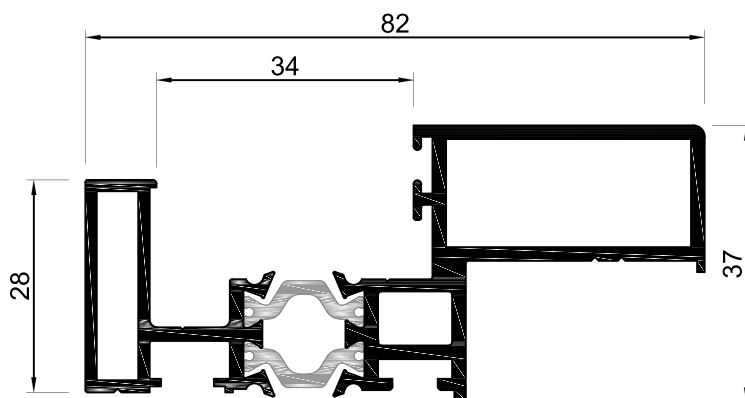

FC.38 Remate Lateral (Versão Semi-Oculta e Oculta)

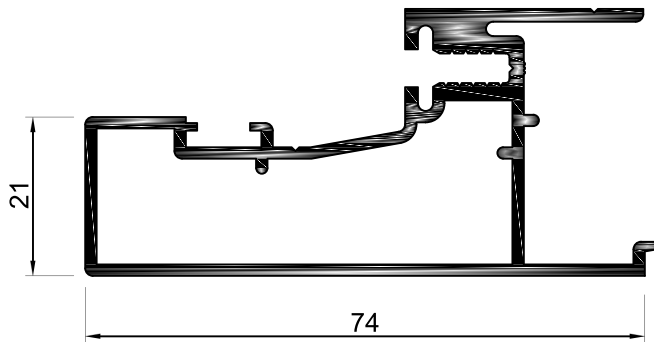

AQ.94 Vareta Cremone

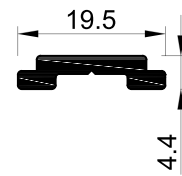

FC.66 Aro Fixo P/ Janelas Projectantes

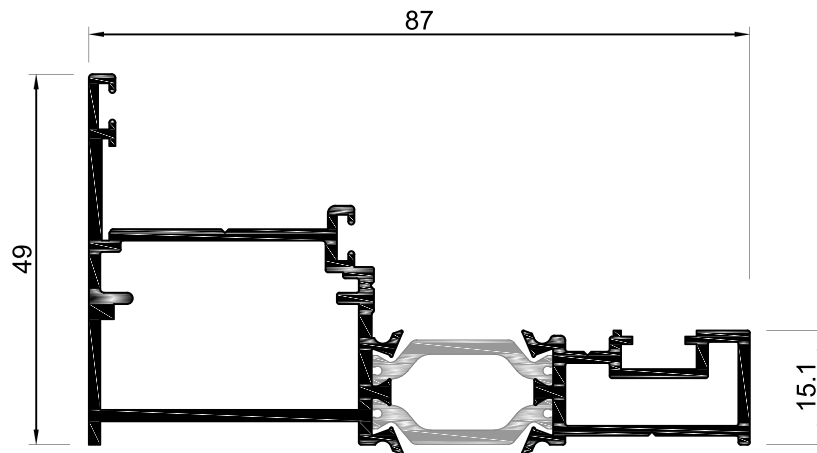

FC.31 Aro Móvel Folha Oculta (Vidro Simples)

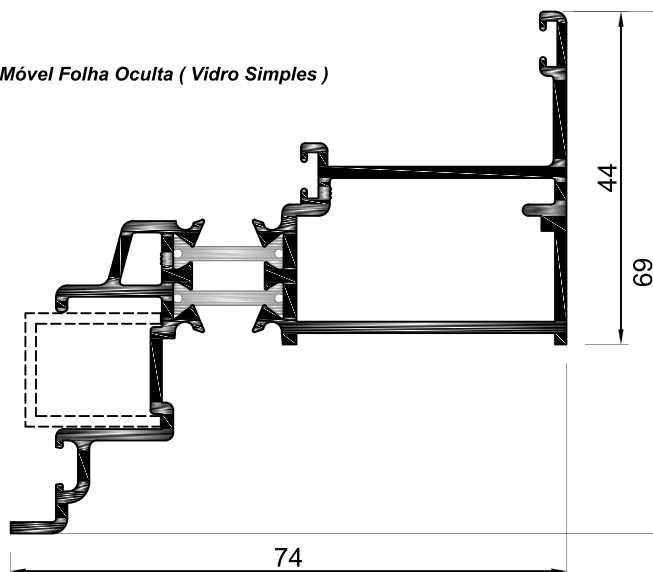

FC.67 Travessa P/ Janelas Projectantes

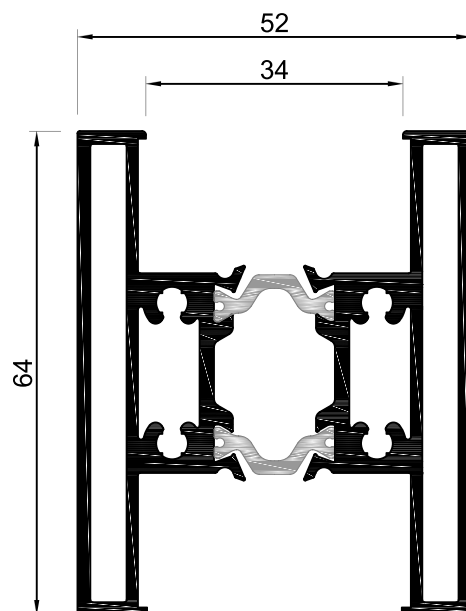

FC.69 Travessa P/ Janelas Projectantes

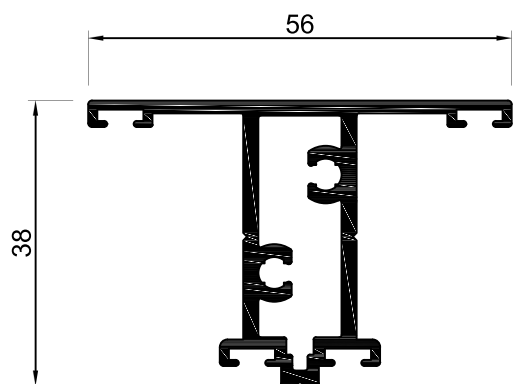

FC.68 Travessa P/ Janelas Projectantes

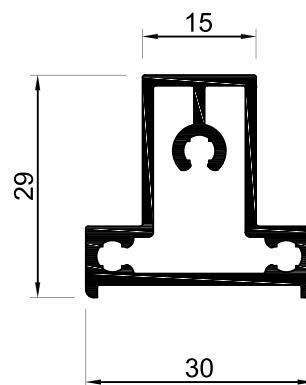

FC.70 Perfil Suporte Vidro (Versão DEC)

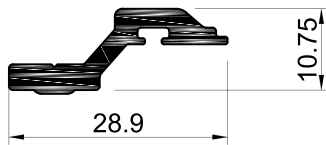

FC.72 Perfil Suporte Vidro (Versão DEC)

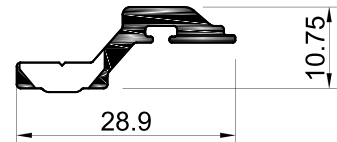

FC.71 Perfil Suporte Vidro (Versão DEC)

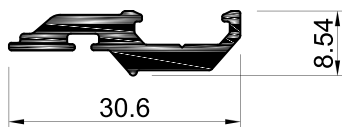

FC.73 Perfil Suporte Vidro (Versão DEC)

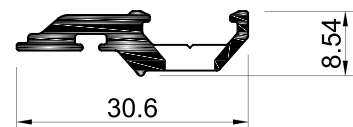

FC.74 Perfil Suporte Vidro (Versão DEC)

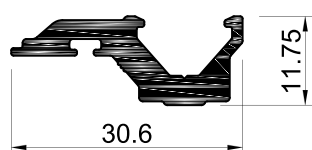

FC.75 Perfil Suporte Vidro (Versão DEC)

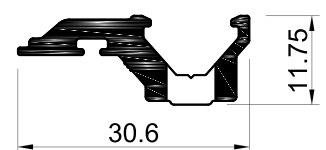



NORTALU[®]

ACESSÓRIOS

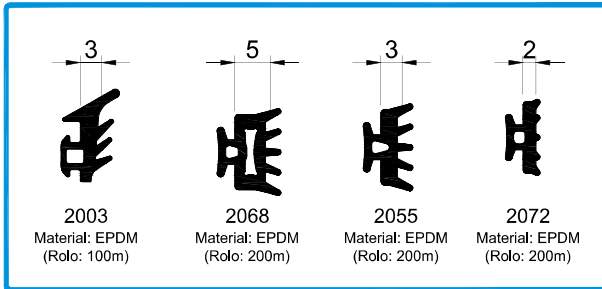

208350 JUNTA DE VEDAÇÃO EXTERIOR 2003
 208427 JUNTA VD 2068
 208289 JUNTA DE BATENTE 2055
 208224 JUNTA VD 2072

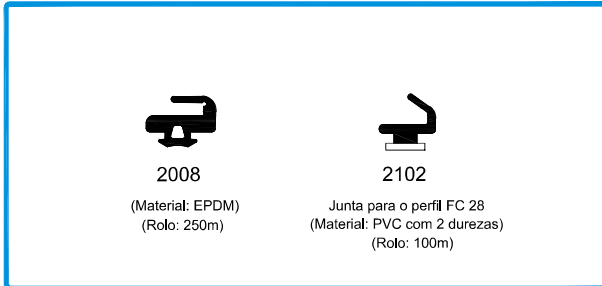

208114 JUNTA DE BATENTE 2008
 208264 JUNTA DE BATENTE 2102

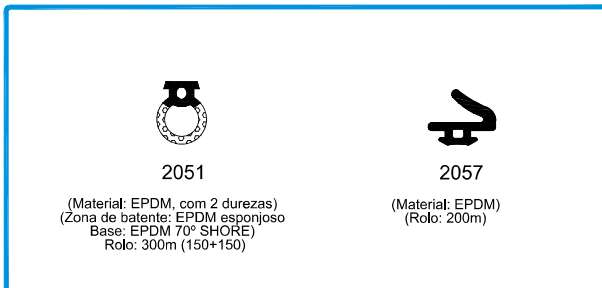

208114 JUNTA DE ESTANQUIDADE 2051
 208008 JUNTA DE ESTANQUIDADE 2057

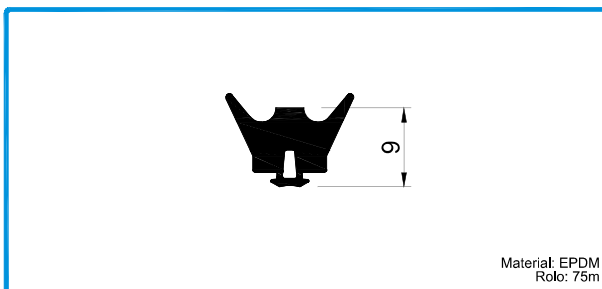

208262 JUNTA DE ESTANQUIDADE 2028

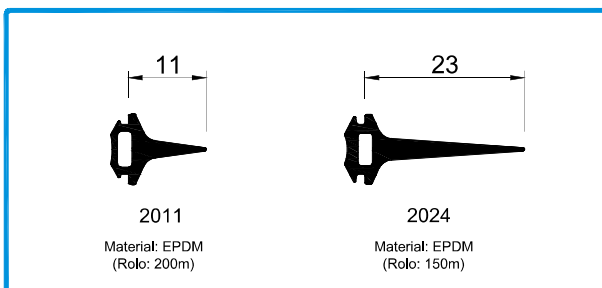

208282 JUNTA EXTERIOR 2011
 208284 JUNTA EXTERIOR 2024

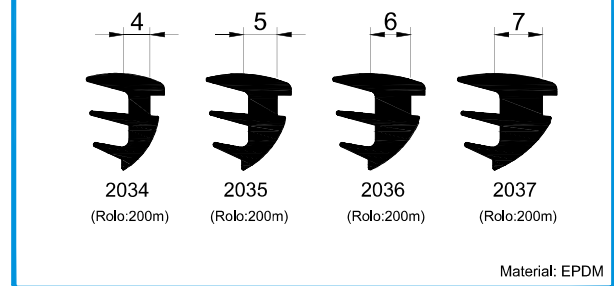
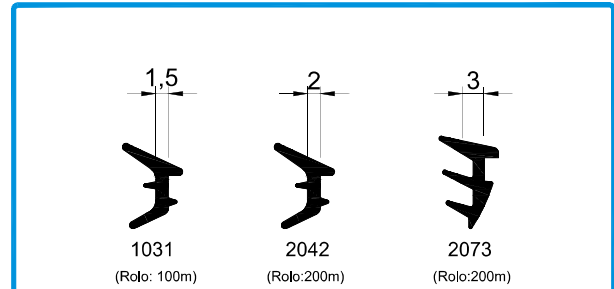

208223 JUNTA DE CUNHA 1031
 208191 JUNTA DE CUNHA 2042
 208195 JUNTA DE CUNHA 2034
 208196 JUNTA DE CUNHA 2035
 208215 JUNTA DE CUNHA 2036
 208904 JUNTA DE CUNHA 2037
 208199 JUNTA DE CUNHA 2073

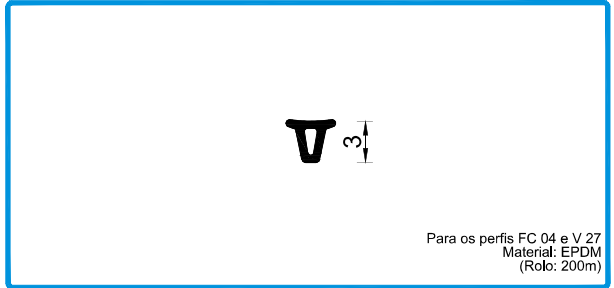

208288 JUNTA EXTERIOR 2141



208476 JUNTA EXTERIOR 2007

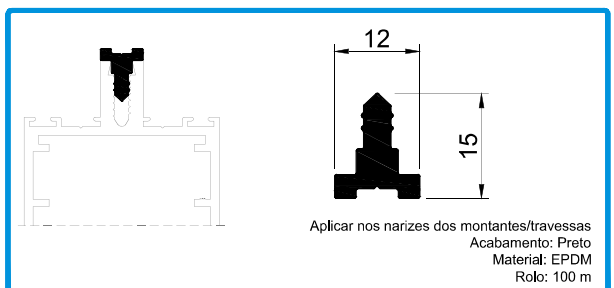

208343 JUNTA 2113

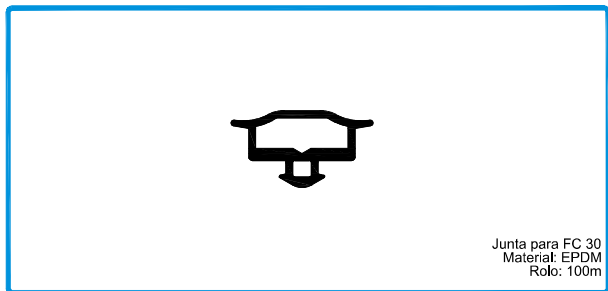

Junta para FC 30
Material: EPDM
Rolo: 100m

208382

JUNTA CENTRAL 2109 Pr.

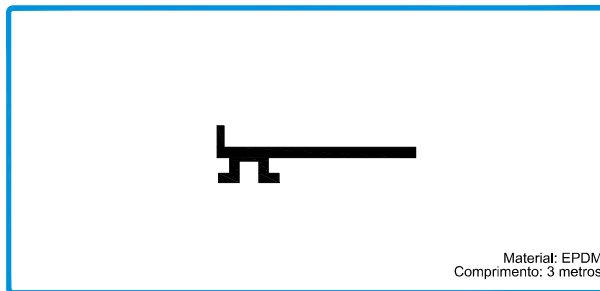

Material: EPDM
Comprimento: 3 metros

208308

JUNTA LIMITADORA 2010

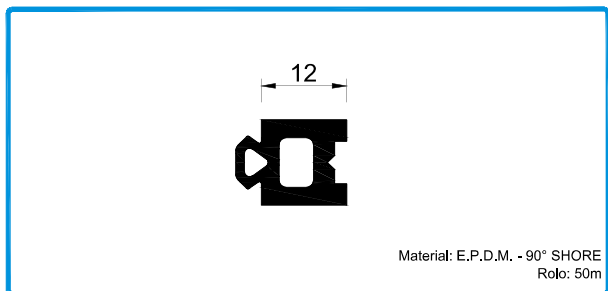

Material: E.P.D.M. - 90° SHORE
Rolo: 50m

208393

JUNTA RT 001 Pr.

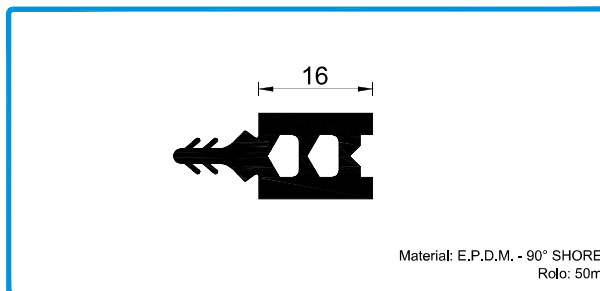

Material: E.P.D.M. - 90° SHORE
Rolo: 50m

208396

JUNTA RT 004

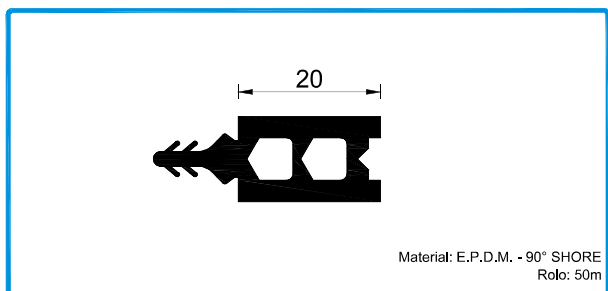

Material: E.P.D.M. - 90° SHORE
Rolo: 50m

208397

JUNTA RT 005

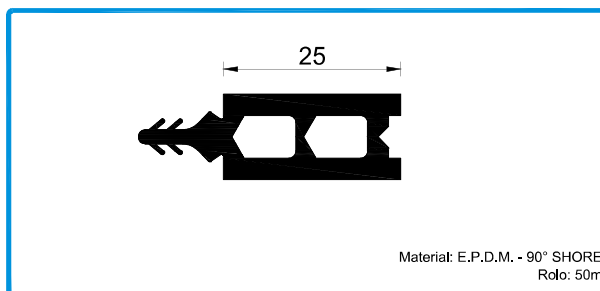

Material: E.P.D.M. - 90° SHORE
Rolo: 50m

208394

JUNTA RT 002 Pr.

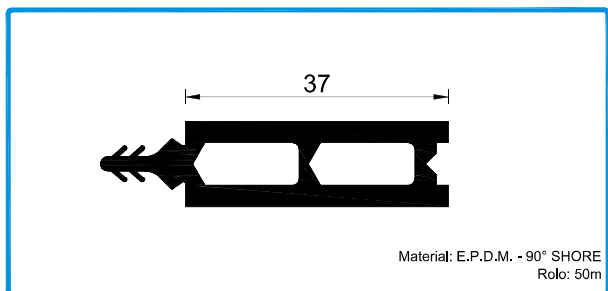

Material: E.P.D.M. - 90° SHORE
Rolo: 50m

208395

JUNTA RT 003

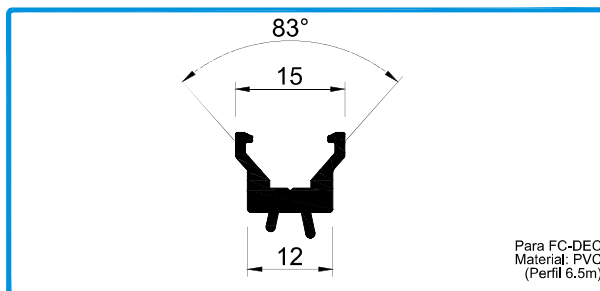

Para FC-DEC
Material: PVC
(Perfil 6.5m)

208493

JUNTA RT 015

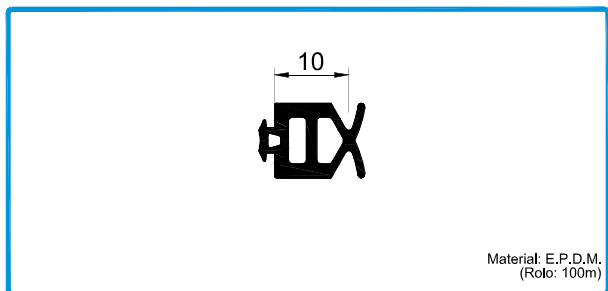

Material: E.P.D.M.
(Rolo: 100m)

208285

JUNTA DE ESTANQUIDADE 2062

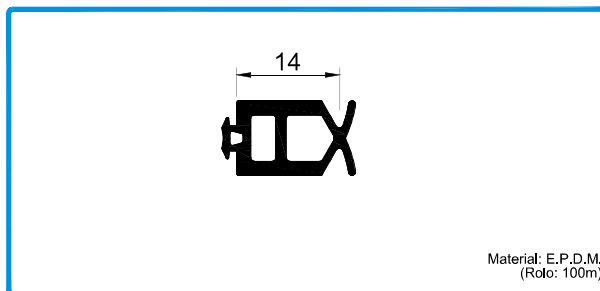

Material: E.P.D.M.
(Rolo: 100m)

208908

JUNTA DE ESTANQUIDADE 2058

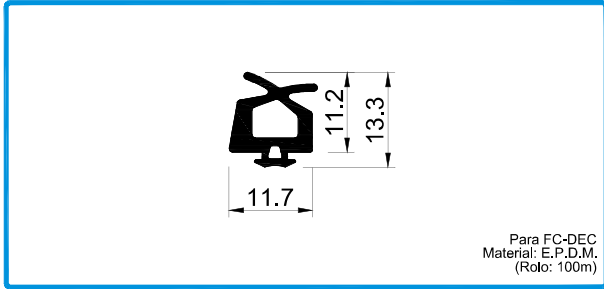

208095

JUNTA VD 2104

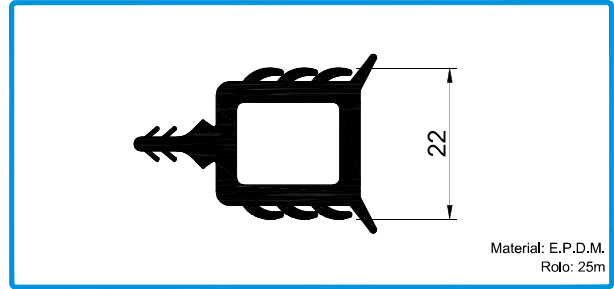

208293

JUNTA DE ESTANQUIDADE 2056

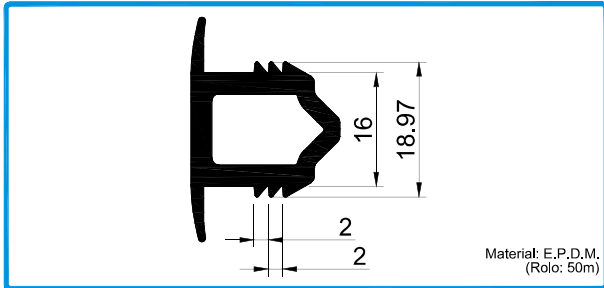

208135

JUNTA 2156

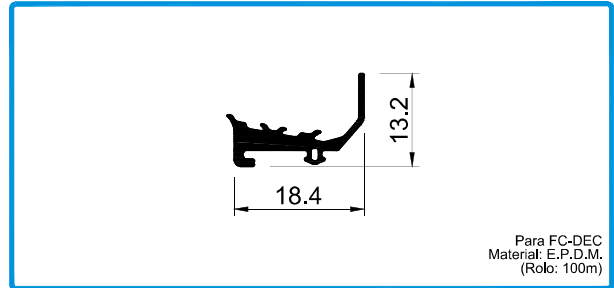

208096

JUNTA VD 2106

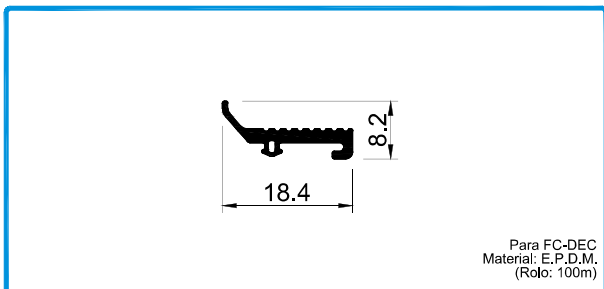

208098

JUNTA VD 2108

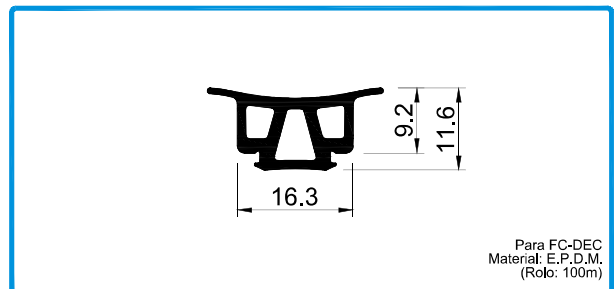

208494

JUNTA VD 2103

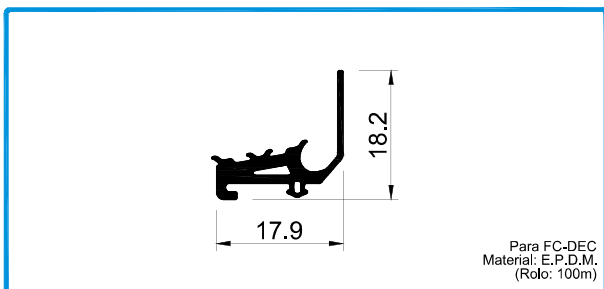

208097

JUNTA VD 2107

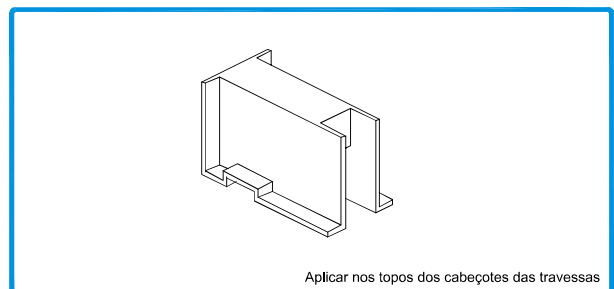

208481

VEDANTE TRAVESSAS VT2801

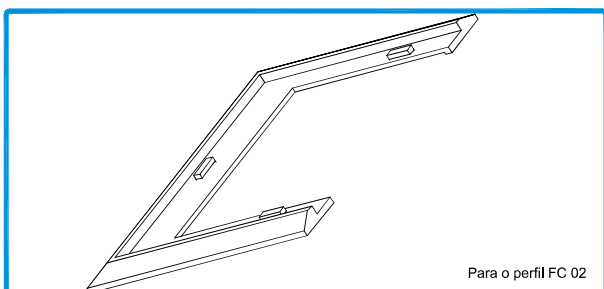

210248

TOPO P/ TRAVESSAS TP2801

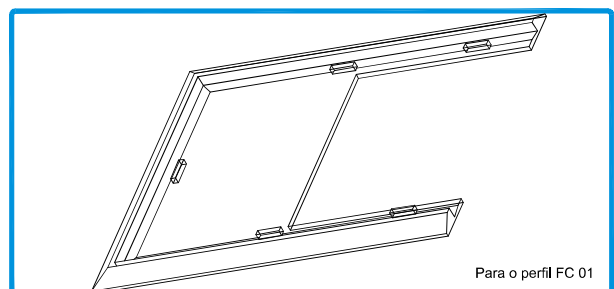

210246

TOPO P/ TRAVESSAS TP24



Para os perfis FC 01; FC 02; FC 24

210219

TOPO FC UNIVERSAL PRETO

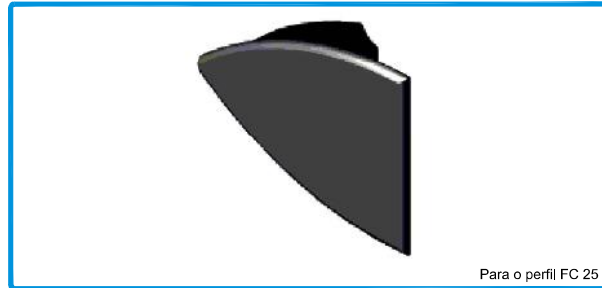

Para o perfil FC 25

210232

TOPO LATERAL FC-25 PRETO

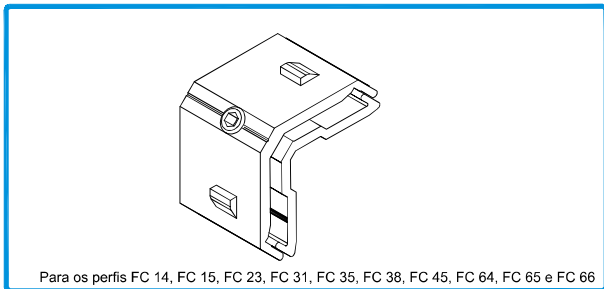

Para os perfis FC 14, FC 15, FC 23, FC 31, FC 35, FC 38, FC 45, FC 64, FC 65 e FC 66

204012

ESQUADRO 26-3214-135

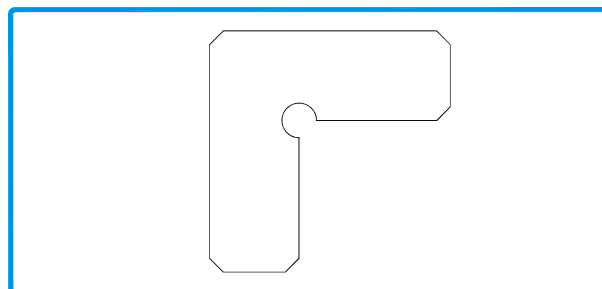

213246

CANTO CR S/SB

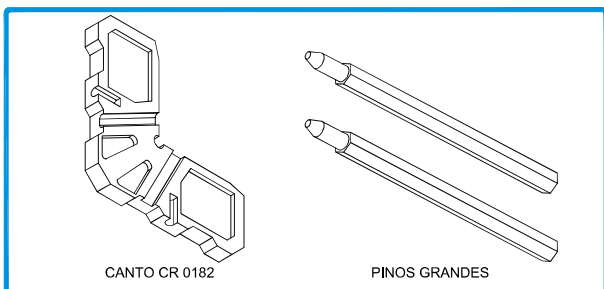

CANTO CR 0182

PINOS GRANDES

213309

CANTO CR 0182 + PINOS GRANDES

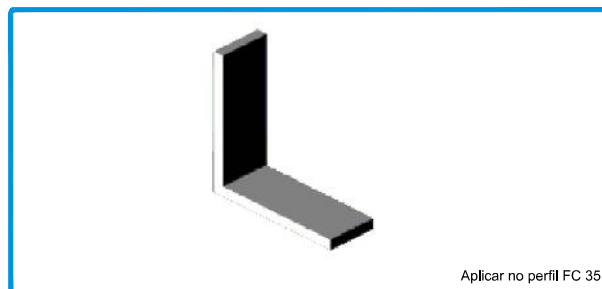

Aplicar no perfil FC 35

000000

CANTO CR 2005

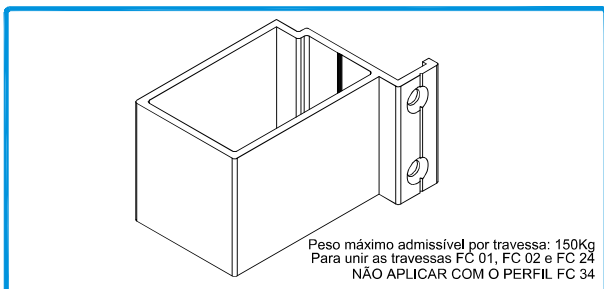

Peso máximo admissível por travessa: 150Kg
Para unir as travessas FC 01, FC 02 e FC 24
NÃO APLICAR COM O PERFIL FC 34

232124

UNIÃO FRONTAL P/ TRAVESSAS UT 27

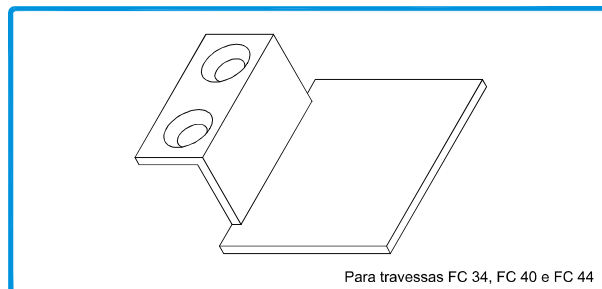

Para travessas FC 34, FC 40 e FC 44

232015

UNIÃO FRONTAL P/ TRAVESSAS INOX



Peso máximo admissível por travessa: 350Kg
Para unir as travessas FC 01, FC 02; FC 24, FC 34, FC 40 e FC 44

232122

UNIÃO P/ TRAVESSAS UT2807

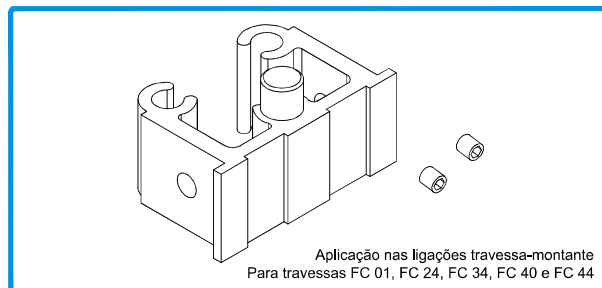

Aplicação nas ligações travessa-montante
Para travessas FC 01, FC 24, FC 34, FC 40 e FC 44

228185

MOLA DE UNIÃO DE TRAVESSA

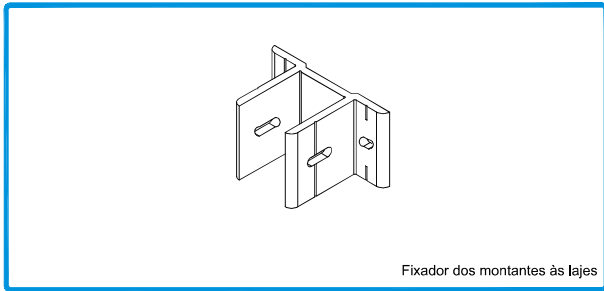

221128

FIXADOR DE MONTANTE 2810

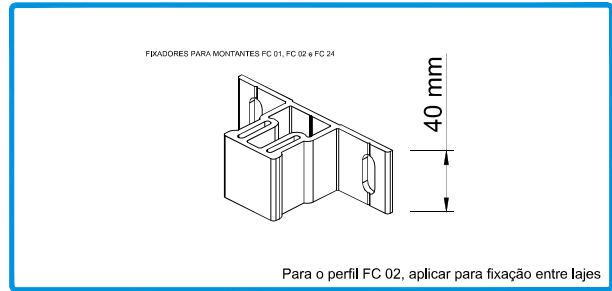

221304

FIXADOR MONTANTE 2811 Bruto

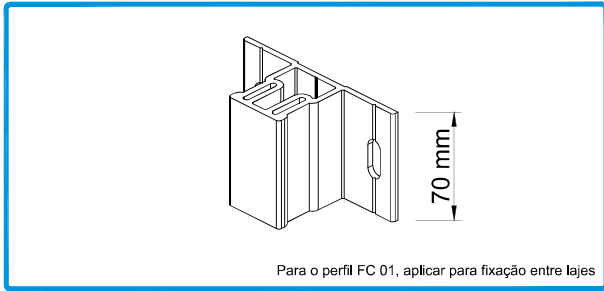

221129

FIXADOR MONTANTE 2812 Bruto

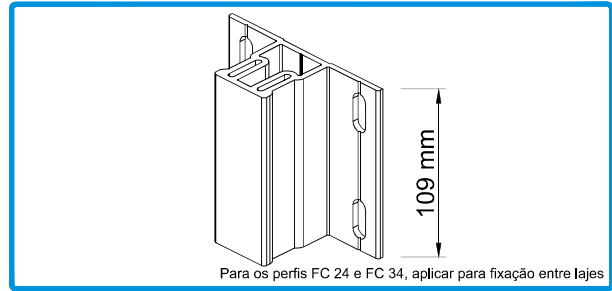

221130

FIXADOR MONTANTE 2813 Bruto

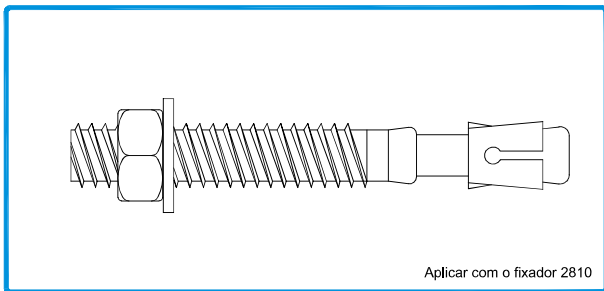

218124

BUCHA SEGM. M8x75 PAR 101 ZINC.

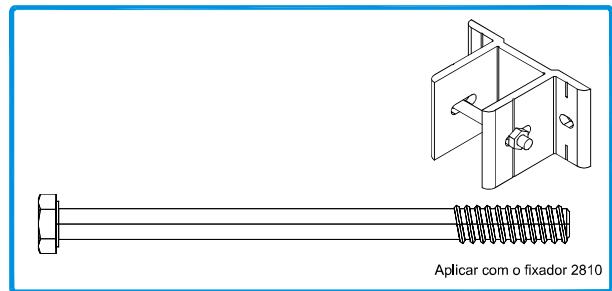

290098
290014

PARAFUSO PAR 100 ZINCADO
PARAFUSO PAR 100 INOX

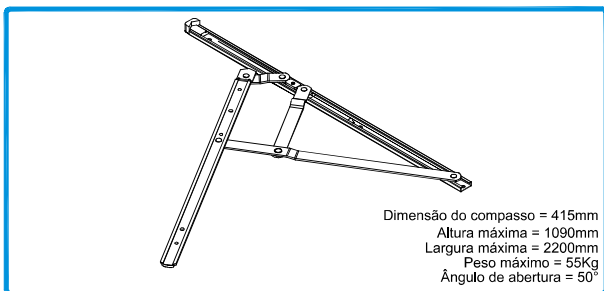

212032

CONJ. BRAÇO PROJETANTE S 400

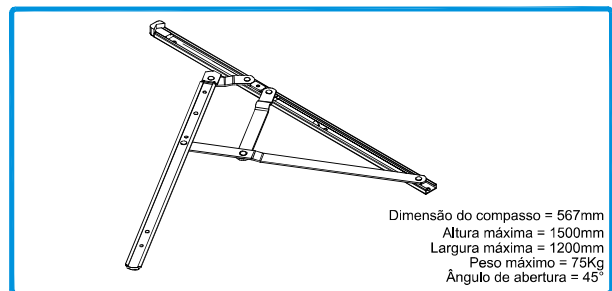

212034

CONJ. BRAÇO PROJETANTE S 550

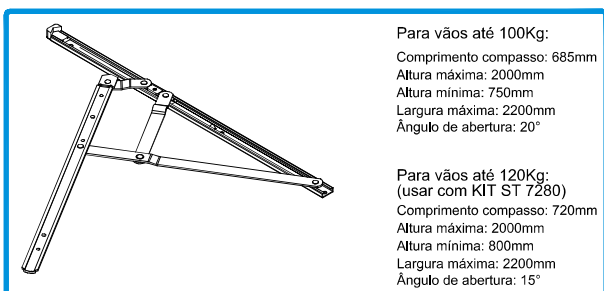

212021
223007

CONJ. BRAÇO PROJETANTE ST 26
KIT AJUSTÁVEL ST280



212218

CONJ. BRAÇO PROJETANTE 18012



212228 CONJUNTO BRAÇO PROJETANTE 18011

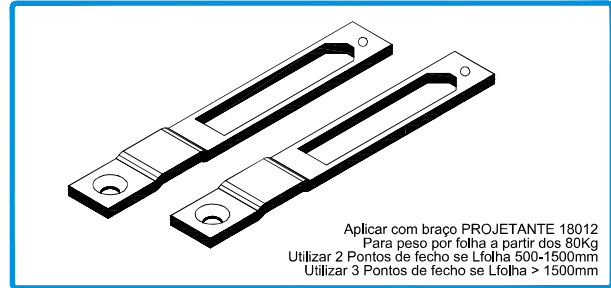

212219 CONJ. LIMITADOR DE ABERTURA BRAÇO PROJ. 18012

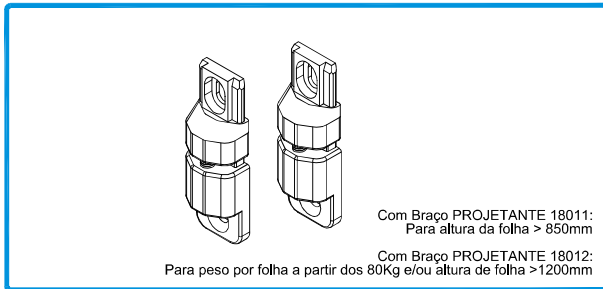

223251 KIT ALTURA AJUSTÁVEL 18012

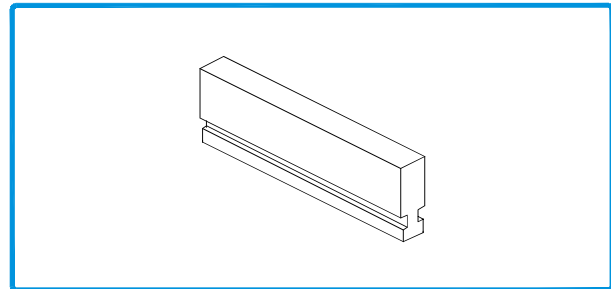

228103 LIMITADOR DISTÂNCIA LD001

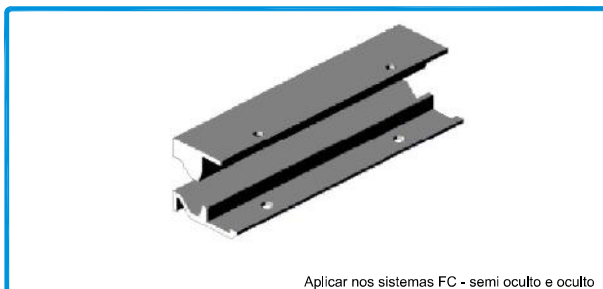

212078 CONJ. FIXAÇÃO INF. 2823



215142 PEÇA FIXAÇÃO FRONTAL 2825

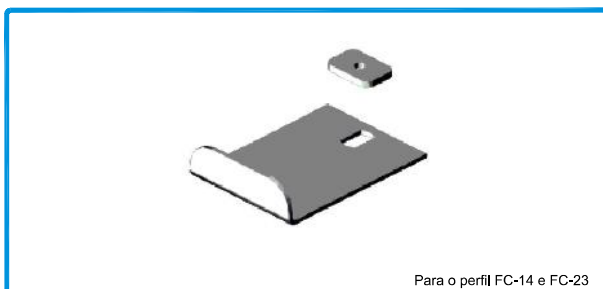

230280 SUPORTE INOX FO



212080 CONJ. FIXAÇÃO LAT. 2824

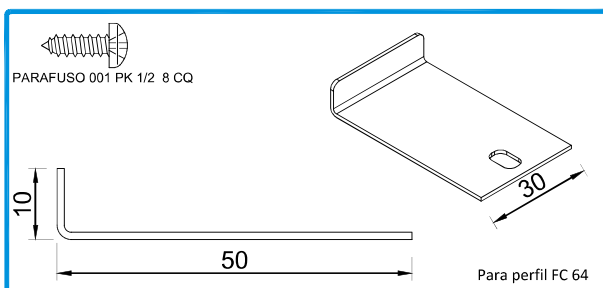

230282 SUPORTE FO INOX 50MM

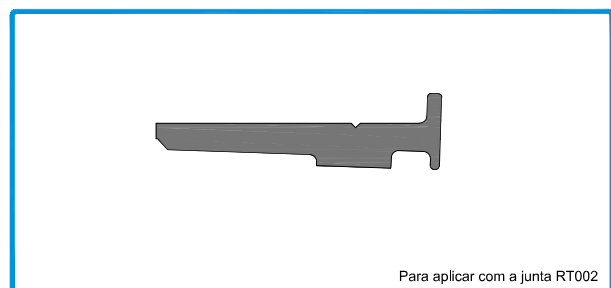

230012 SUPORTE FC AUTO-PORTANTE 002

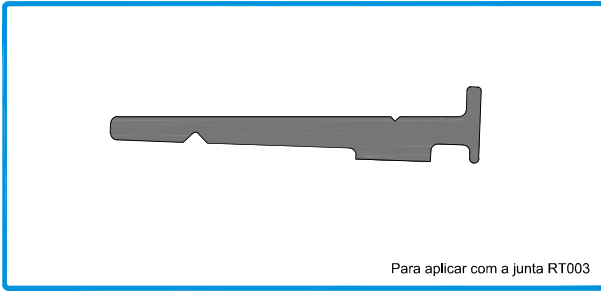

Para aplicar com a junta RT003

230013

SUPORTE FC AUTO-PORTANTE 003

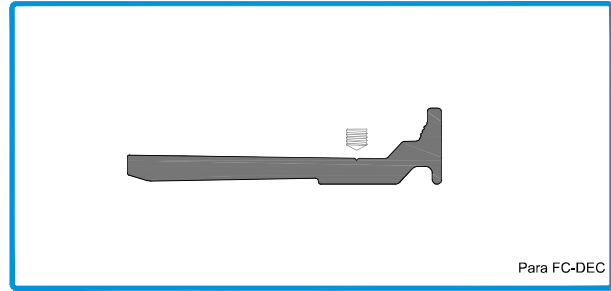

Para FC-DEC

230286

SUPORTE FC AUTO-PORTANTE 005

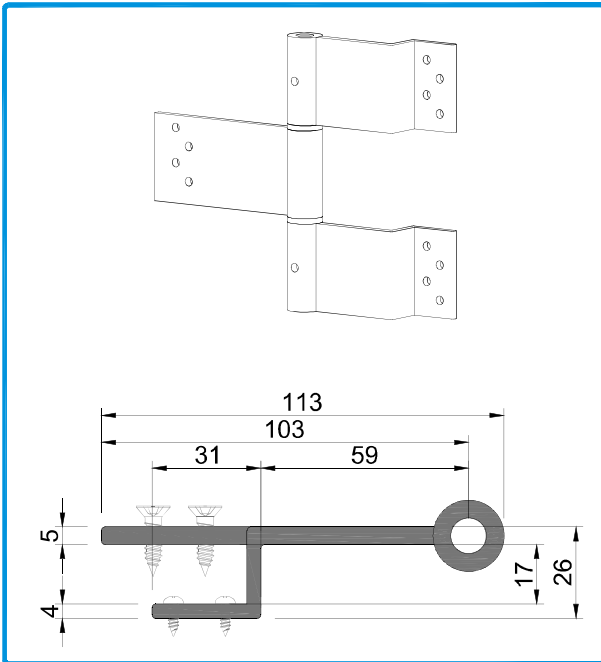

202234

DOBRADIÇA INOX PARA SÉRIE FC

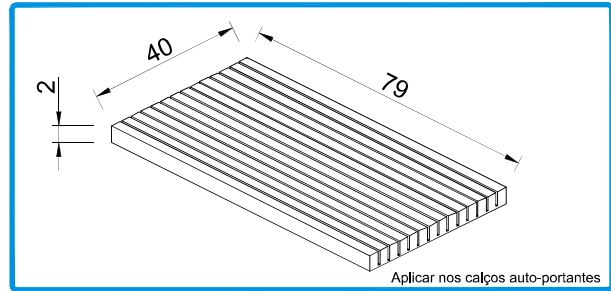

Aplicar nos calços auto-portantes

218113

CALÇO PARA VIDRO 79X40X2



213016

CANTO REENVIO 9312

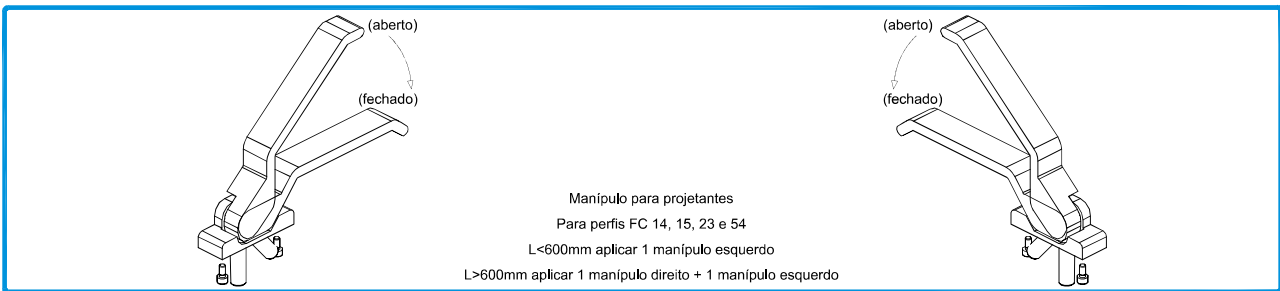

Manipulo para projetantes
Para perfis FC 14, 15, 23 e 54
L<600mm aplicar 1 manipulo esquerdo
L>600mm aplicar 1 manipulo direito + 1 manipulo esquerdo

416003

416004

MANÍPULO ARTICULADO i33 DIR.

MANÍPULO ARTICULADO i33 ESQ.

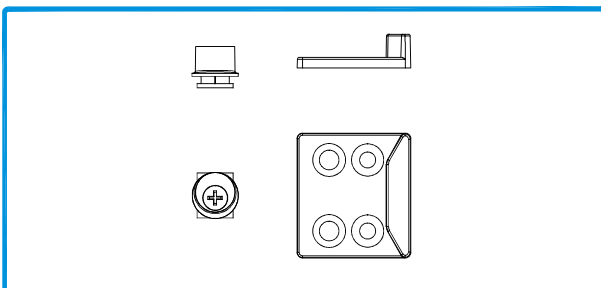

212229

CONJ. PONTO FECHO SUPLEMENTAR 9313

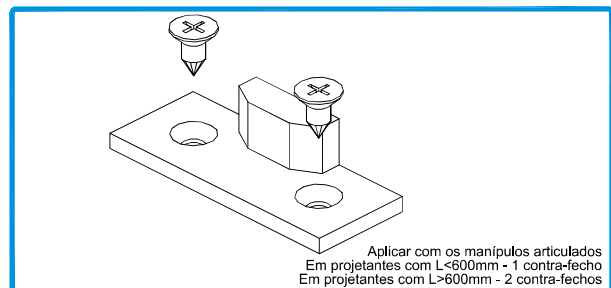

Aplicar com os manipulados articulados
Em projetantes com L<600mm - 1 contra-fecho
Em projetantes com L>600mm - 2 contra-fechos

202088

CONTRA FECHO 5708

SÉRIE FC

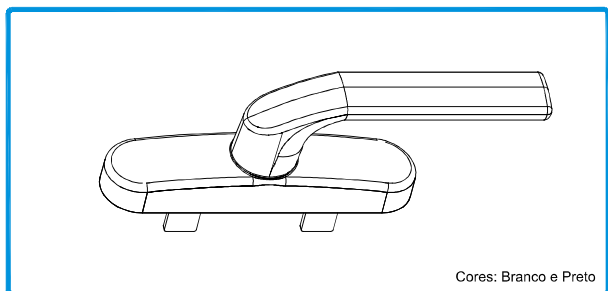

Cores: Branco e Preto

200143

CREMONE 620M 27

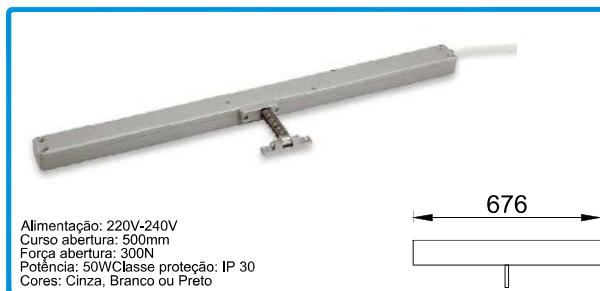

Alimentação: 220V-240V
Curso abertura: 500mm
Força abertura: 300N
Potência: 50W Classe proteção: IP 30
Cores: Cinza, Branco ou Preto

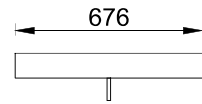

212640

ACIONADOR 40837Z

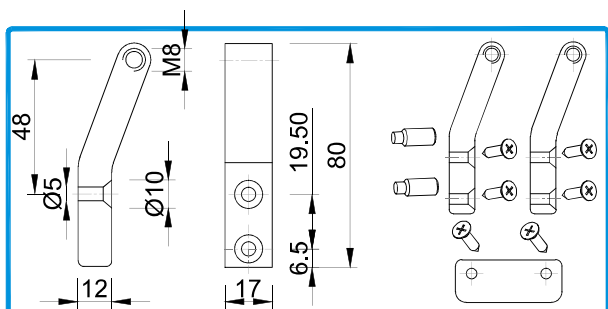

223469
223471
223472

KIT FIXAÇÃO ACIONADOR 40941H (Cinz.)
KIT FIXAÇÃO ACIONADOR 40942I (Pr.)
KIT FIXAÇÃO ACIONADOR 40943J (Br.)



Acionador para janelas PROJETANTES e basculantes
Voltagem: 100Vac - 240Vac
Inversão de marcha: por inversão de polaridade
Abertura: 500mm
Força: 600N
Classe de proteção: IP 30
Cores: Natural, Preto, Branco

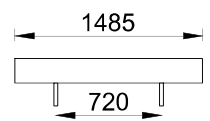

212036

ACIONADOR ELÉCTRICO DUPLO 240Vac 40989D



Compatível com comandos
Compatível com acionadores 220-240VAC

299089

RECETOR RÁDIO 230VAC TT2N



214269

COMANDO DIST. RF P1



Para fixação do perfil FC 04 sem junta RT 001P aplicar com anilha AN 001

290226

PARAFUSO PAR 004 PK INOX PH 7/8x12 CQ

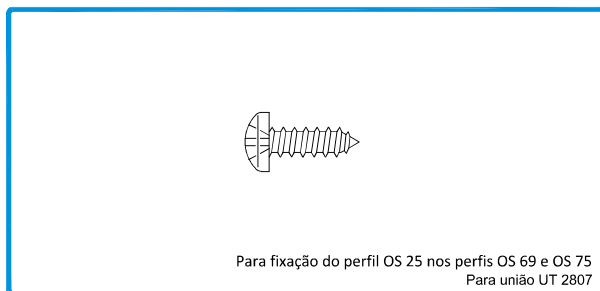

Para fixação do perfil OS 25 nos perfis OS 69 e OS 75
Para união UT 2807

290260

PARAF. PAR 001 PK INOX PH 1/2x8 CQ

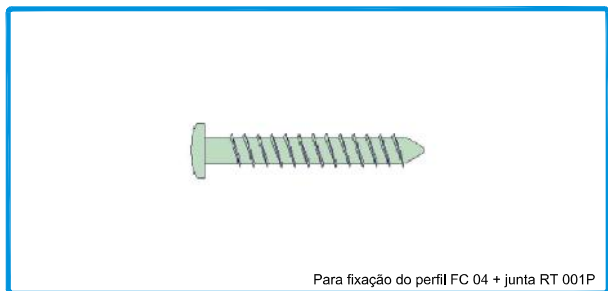

Para fixação do perfil FC 04 + junta RT 001P

290165
290262
217104

PARAFUSO PK INOX PH 1 1/4x10 CQ
PAR. PAR 003 PK INOX PH 1 1/2x10 CQ
ANILHA COLADA 6.3 AN 001 INOX

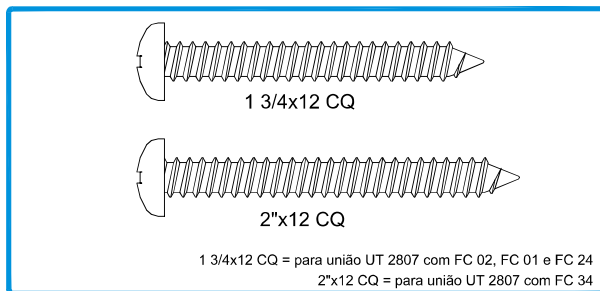

1 3/4x12 CQ

2"x12 CQ

1 3/4x12 CQ = para união UT 2807 com FC 02, FC 01 e FC 24
2"x12 CQ = para união UT 2807 com FC 34

290264
000000

PARAFUSO PAR 005 PK 1 3/4x12 CQ
PARAFUSO PK INOX PH 2"x12 CQ

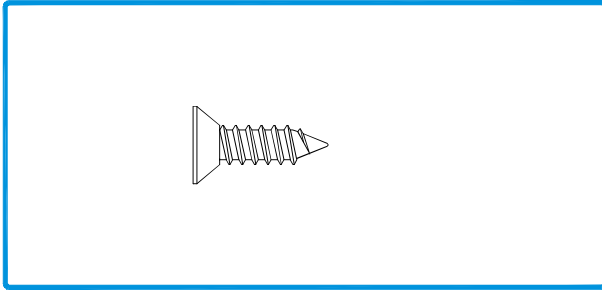

000000 PARAFUSO AUTOROSCANTE DIN7982 5,5 X19

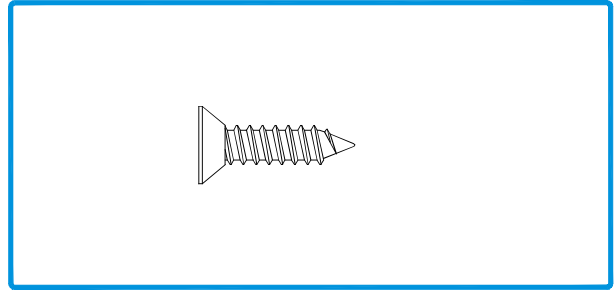

000000 PARAFUSO AUTOROSCANTE DIN7982 5,5 X22

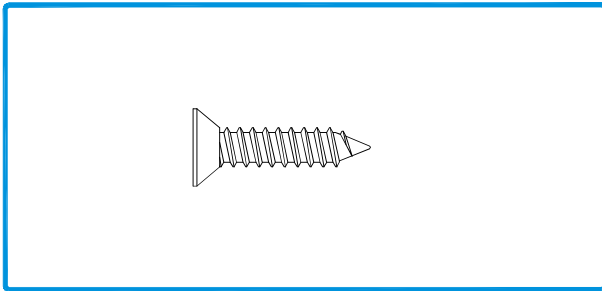

000000 PARAFUSO AUTOROSCANTE DIN7982 5,5 X25

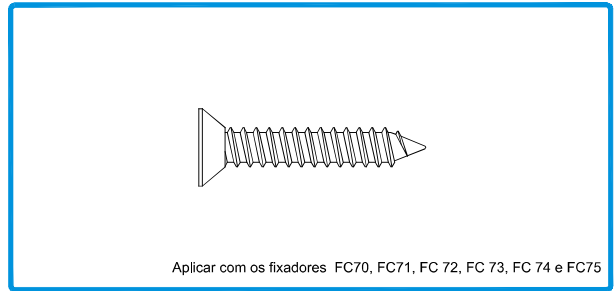

Aplicar com os fixadores FC70, FC71, FC 72, FC 73, FC 74 e FC75

000000 PARAFUSO AUTOROSCANTE DIN7982 5,5 X32

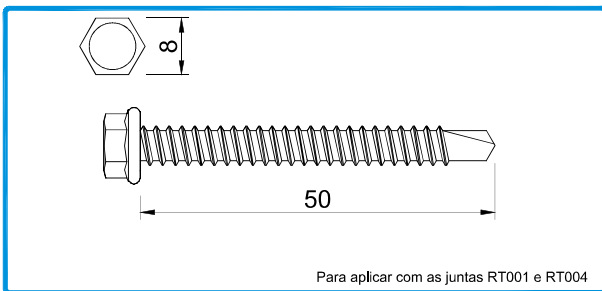

Para aplicar com as juntas RT001 e RT004

290459 REF.º PARAFUSO DIN 7504 5.5x50 Dmet

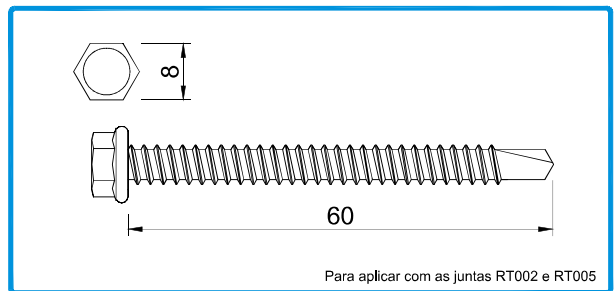

Para aplicar com as juntas RT002 e RT005

290460 REF.º PARAFUSO DIN 7504 5.5x60 Dmet

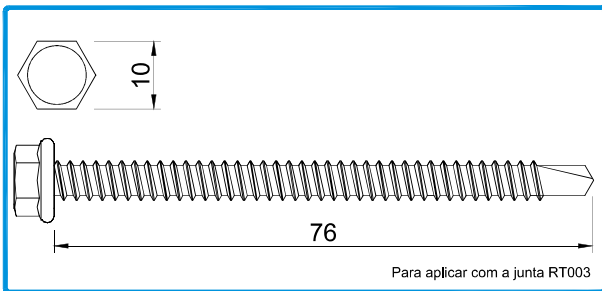

Para aplicar com a junta RT003

290461 REF.º PARAFUSO DIN 7504 6.3x76 Dmet

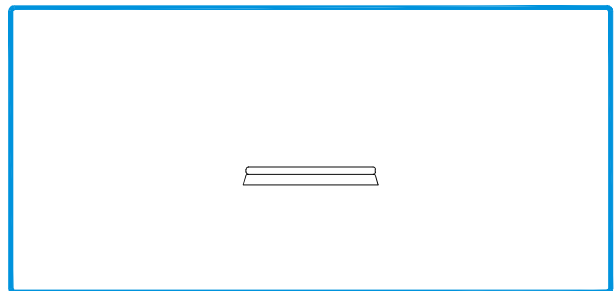

217104 ANILHA AN 001

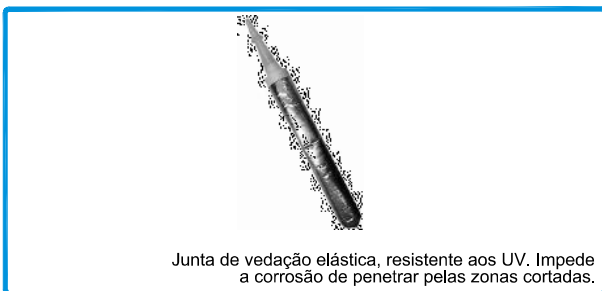

Junta de vedação elástica, resistente aos UV. Impede a corrosão de penetrar pelas zonas cortadas.

208019 SELA JUNTAS 150gr. (Cinza)



Limpeza de alumínio lacado ou anodizado. Para preparação das superfícies a serem unidas e limpeza final.

208704 PRODUTO LIMPEZA DE ALUMÍNIO (1L) Transparente



NORTALU[®]

PORMENORES TÉCNICOS

MAPA DE ENCHIMENTOS PARA FACHADA ESTRUTURAL COM AS JUNTAS RT

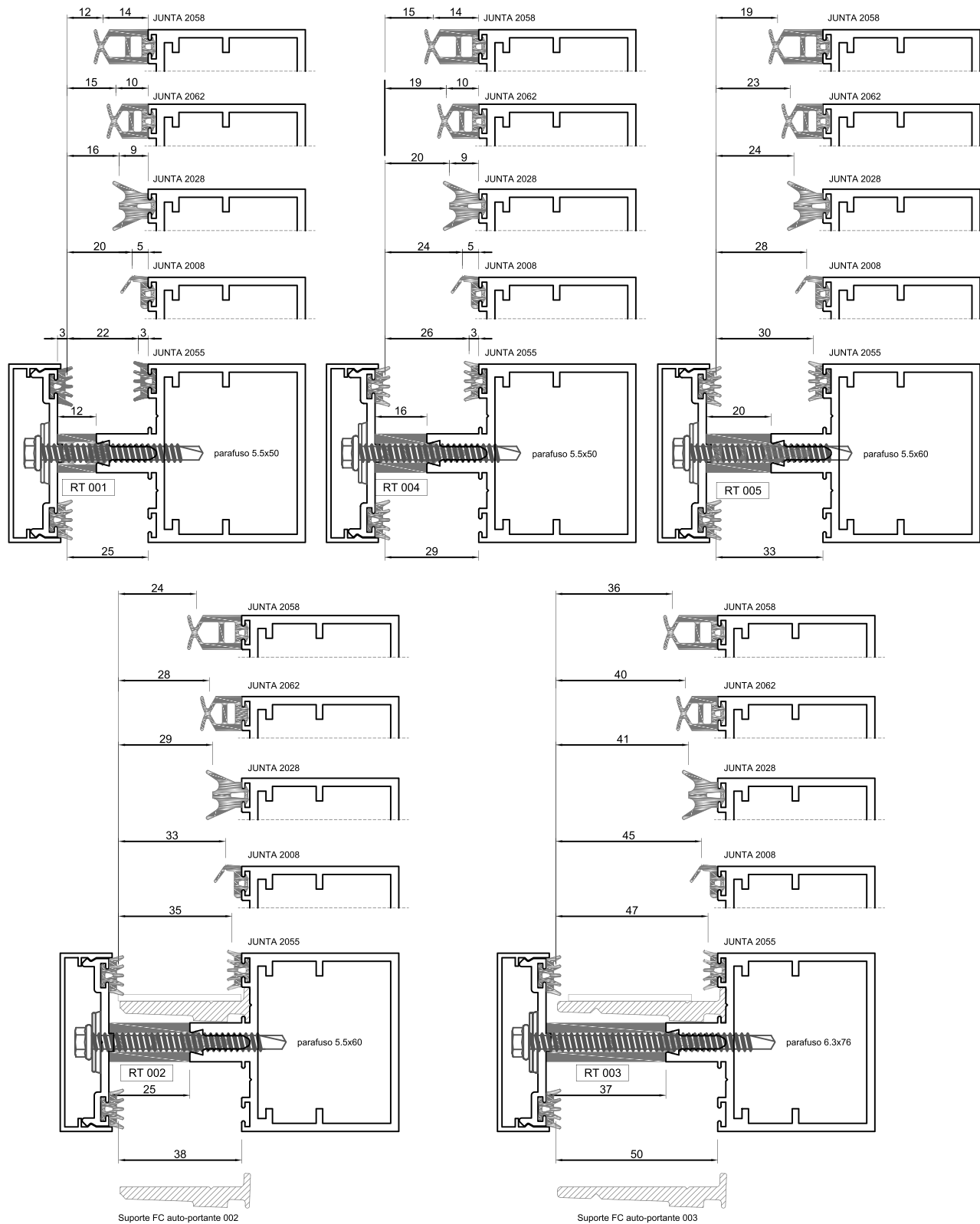

Nota: Na utilização das juntas RT002 ou RT003 aplicar os suportes FC auto-portantes para suporte dos vidros juntamente com o calço para vidro 79x40x2mm

FACHADA ESTRUTURAL: PORMENORES 1 E 2

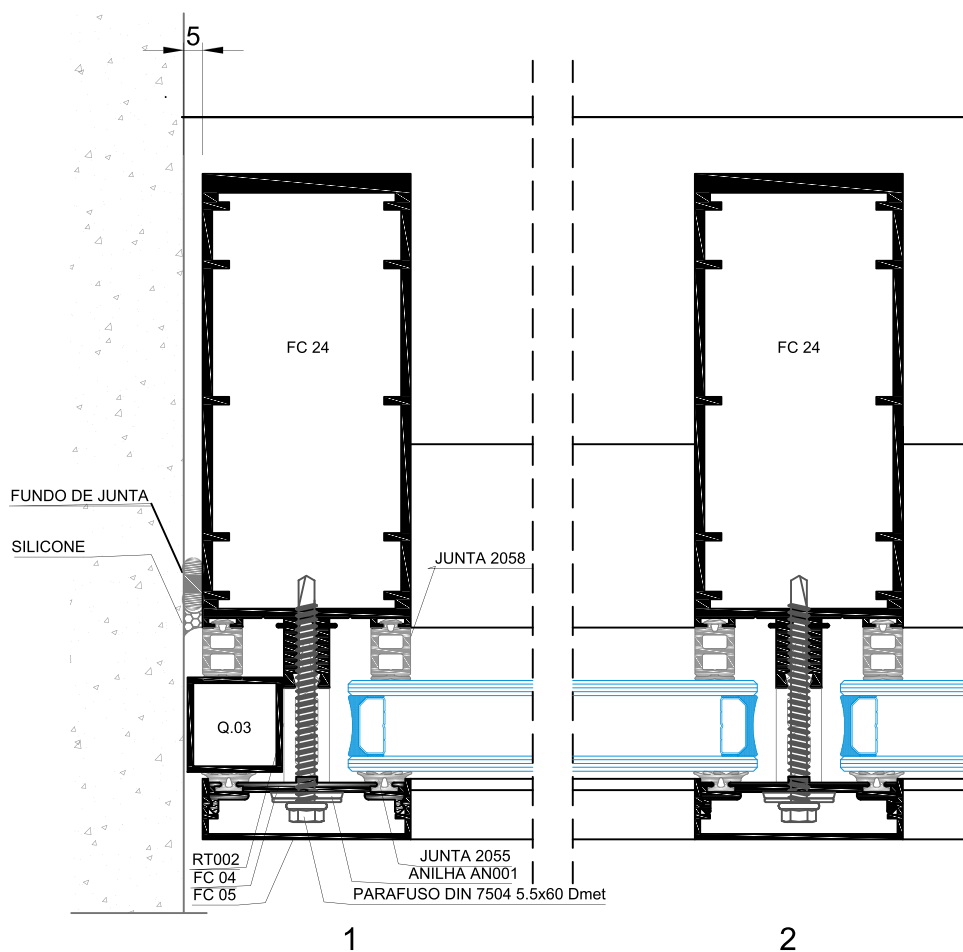
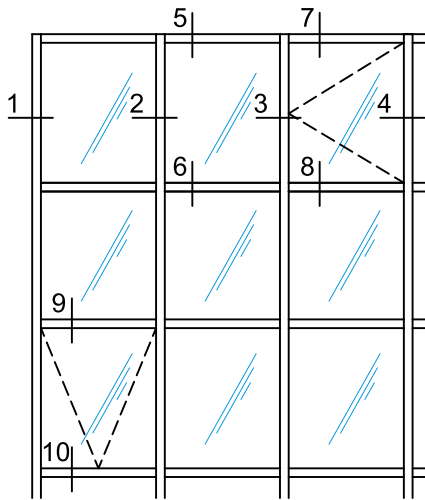

ESCALA 1:2

FACHADA ESTRUTURAL: PORMENORES 3 E 4

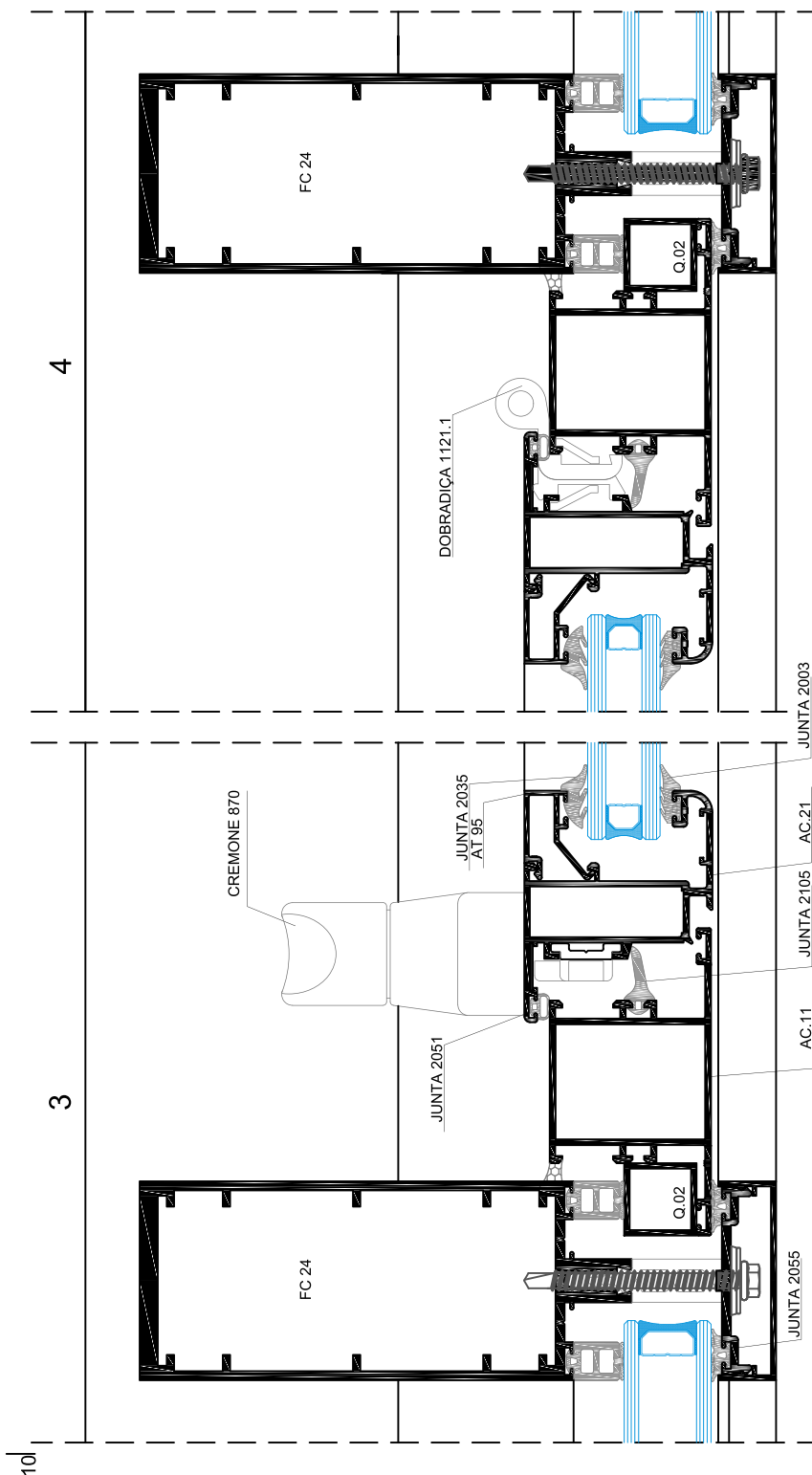
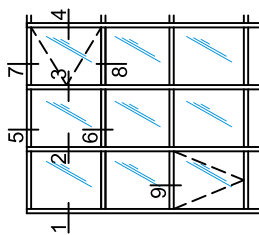

ESCALA 1:2

FACHADA ESTRUTURAL: PORMENORES 7 E 8 COM VÃO OSCILO-BATENTE

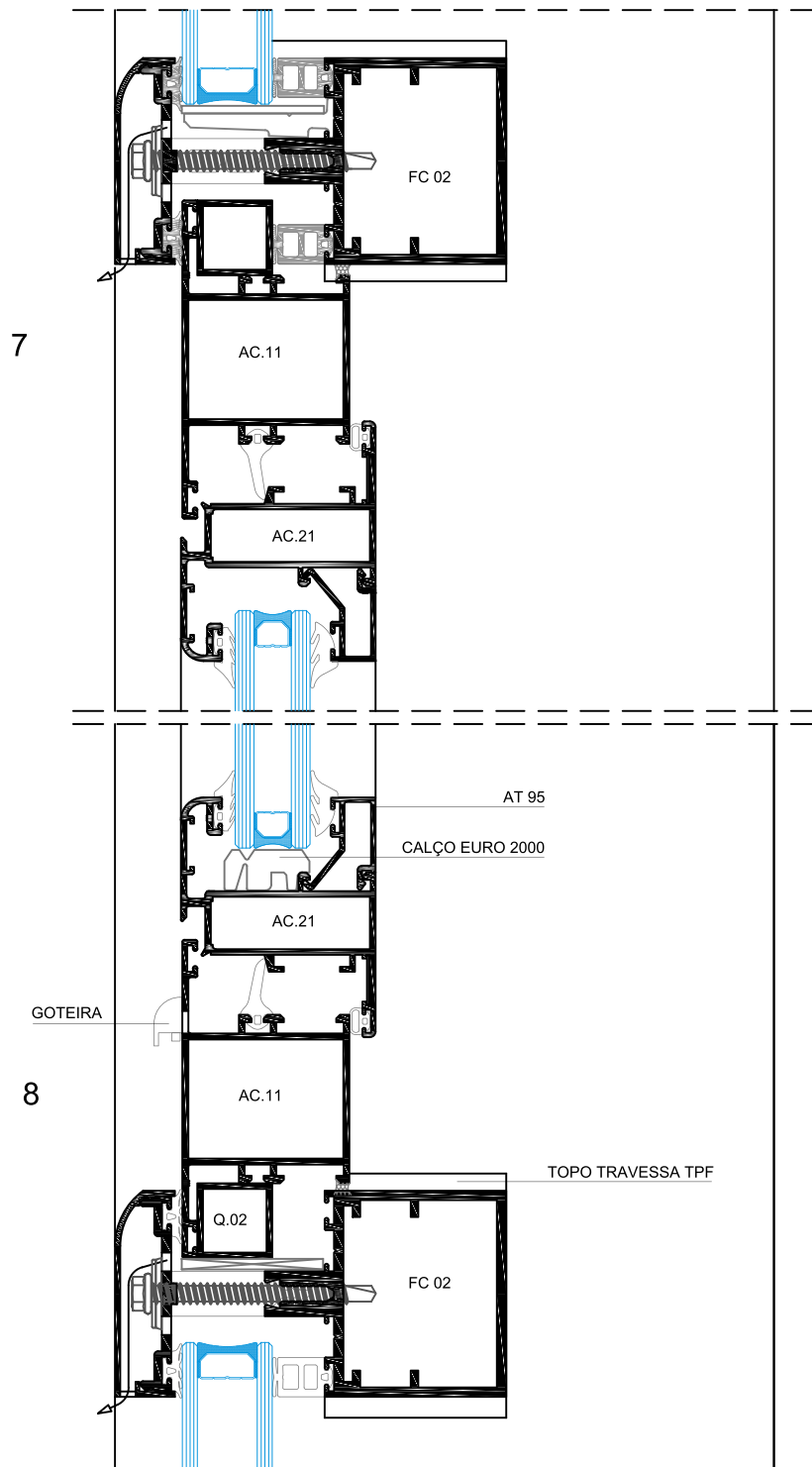
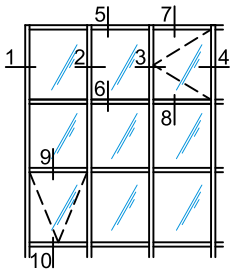

ESCALA 1:2

FACHADA ESTRUTURAL: PORMENORES 7 E 8 COM VÃO OSCILO-BATENTE

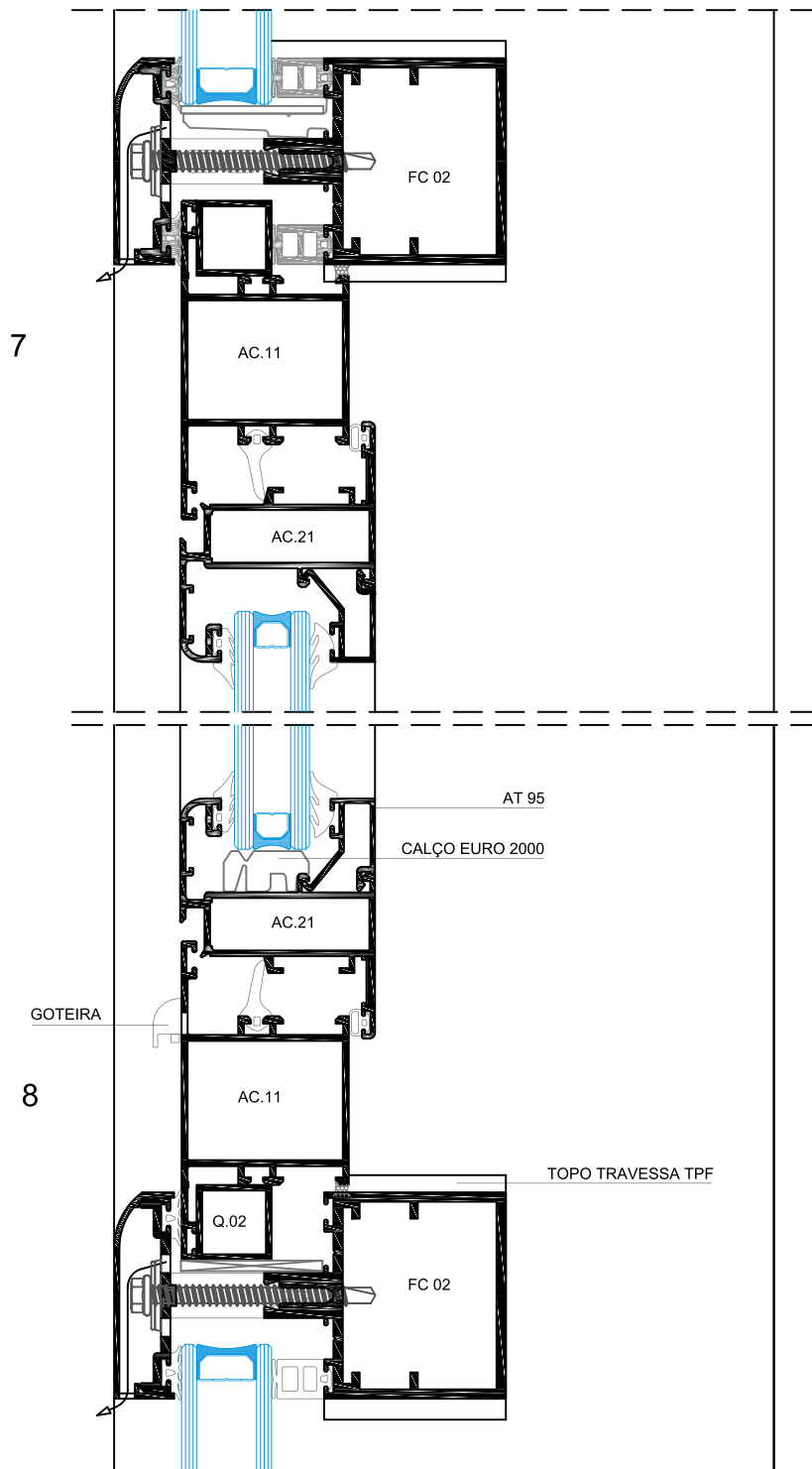
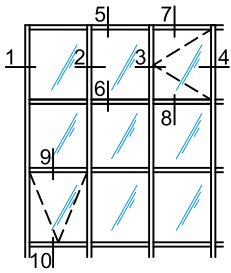

ESCALA 1:2

FACHADA ESTRUTURAL: PORMENORES 9 E 10 COM VÃO PROJETANTE

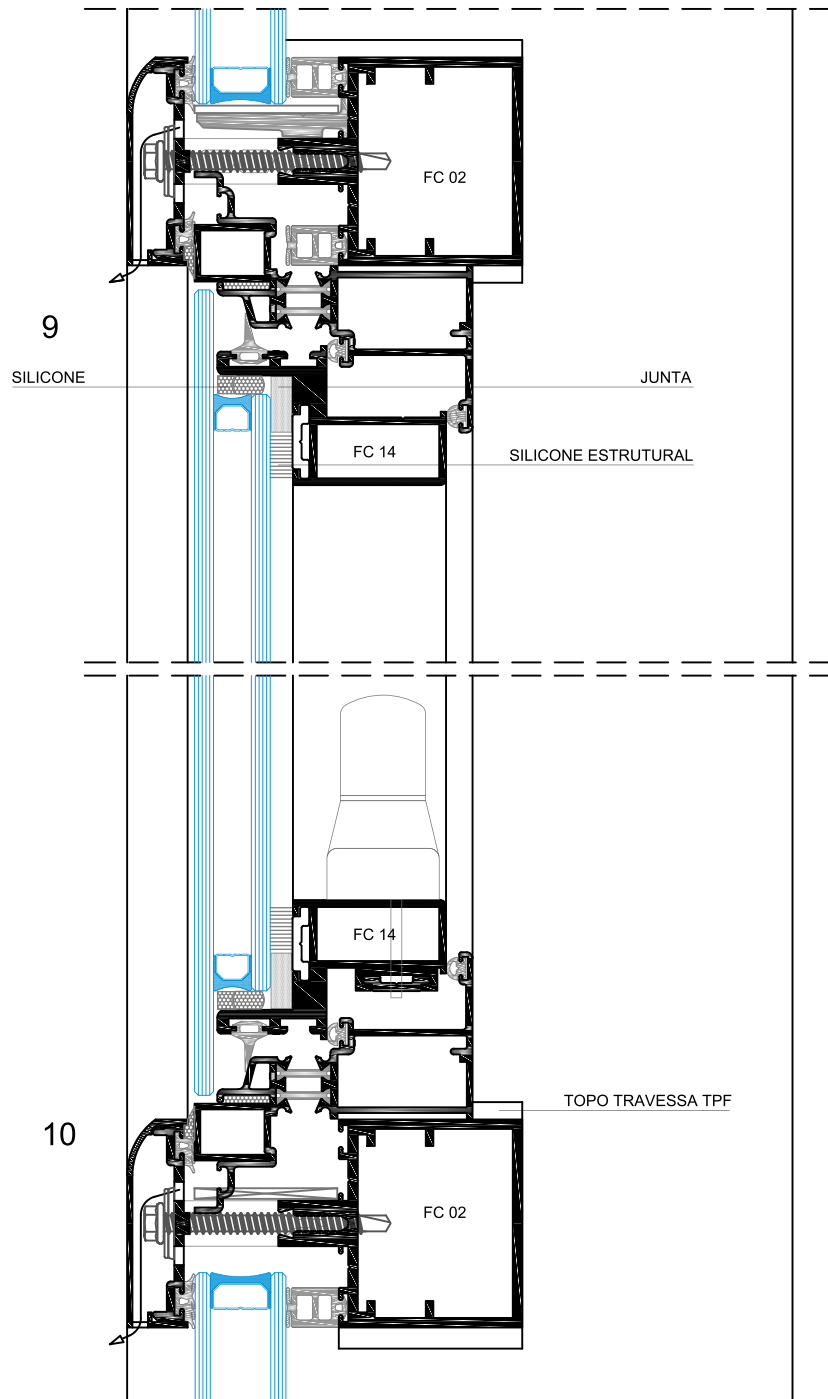
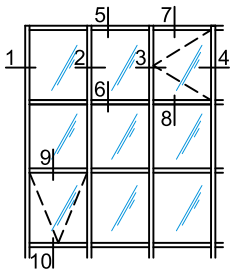

ESCALA 1:2

FACHADA ESTRUTURAL: APLICAÇÃO DOS PERFIS PARA JUNTA DE DILATAÇÃO COM FIXAÇÃO ENTRE LAJE

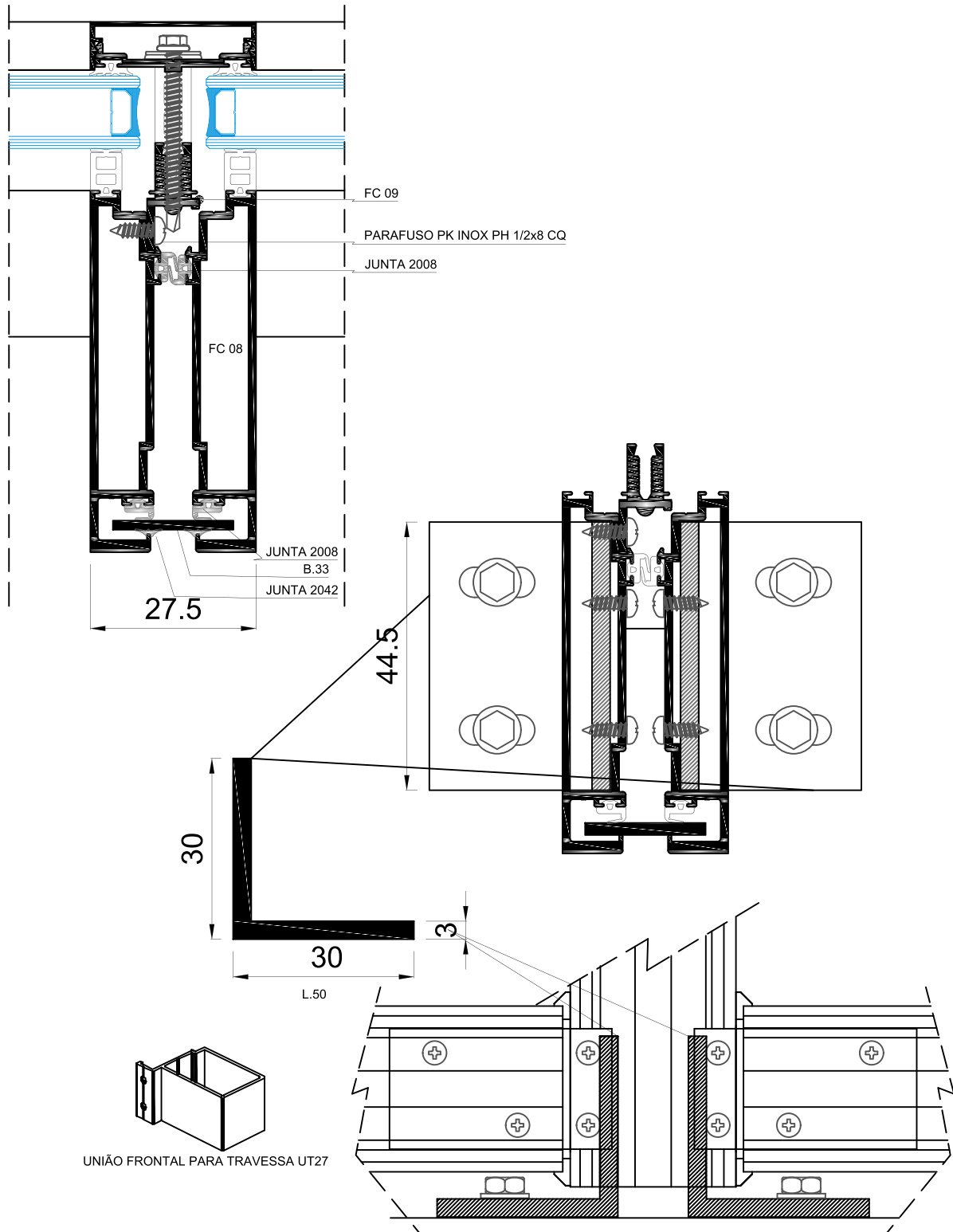

ESCALA 1:2

FACHADA ESTRUTURAL: CANTO 90°

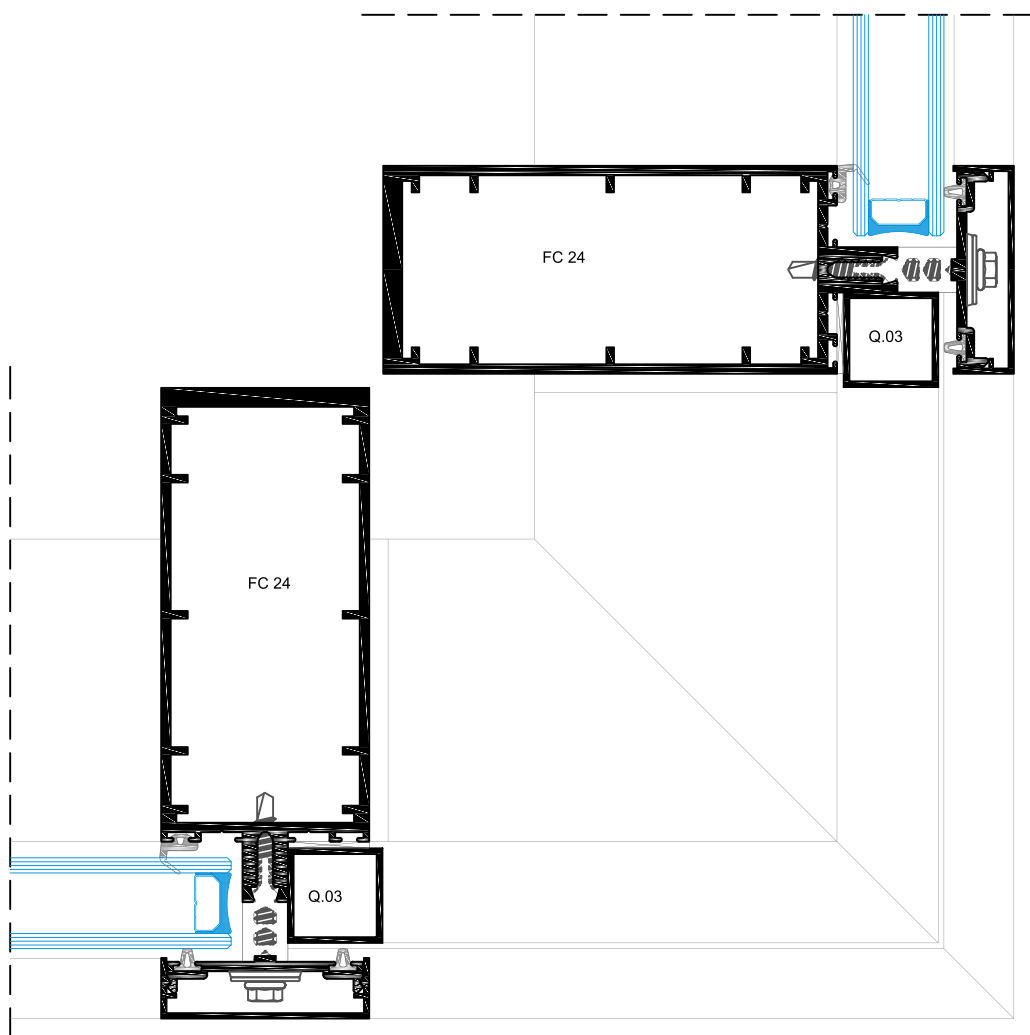

ESCALA 1:2

FACHADA ESTRUTURAL: CANTO 90° COM CANTO EM VIDRO

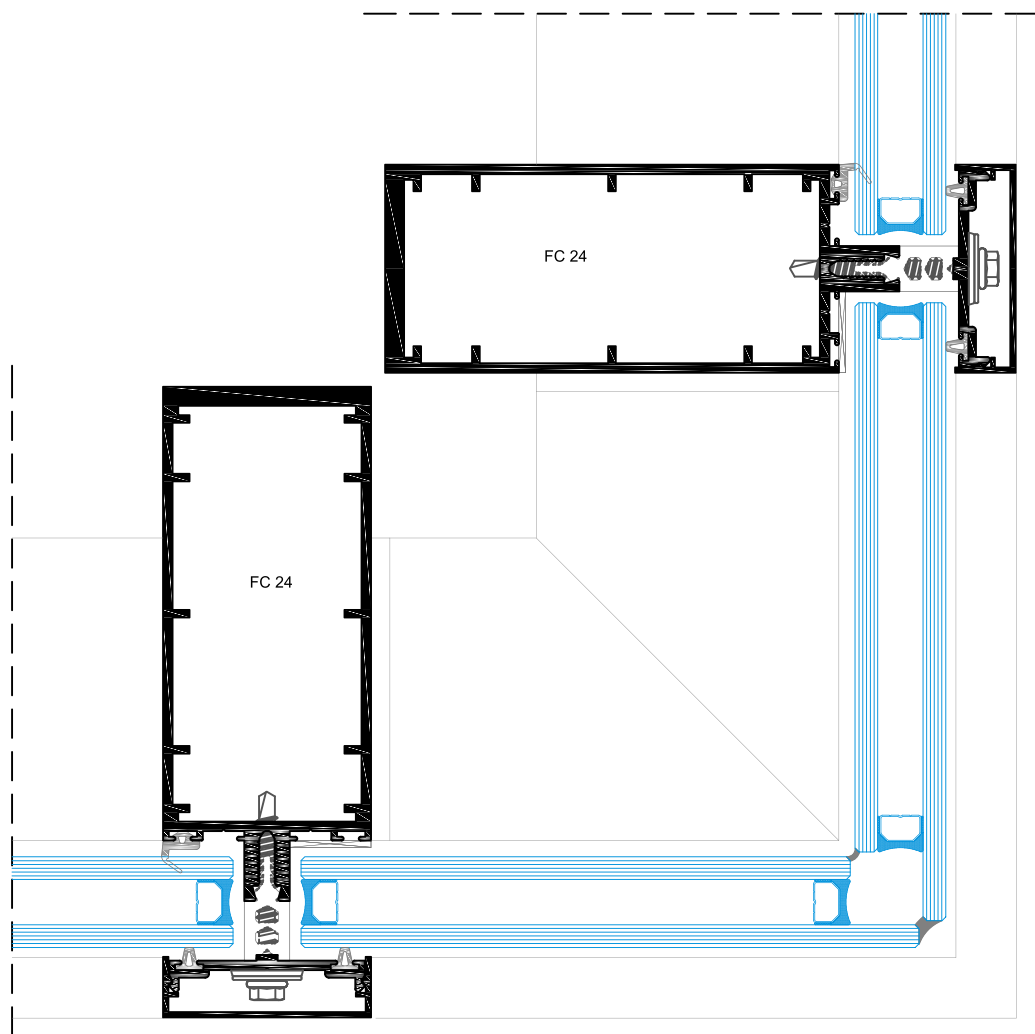

ESCALA 1:2

FACHADA ESTRUTURAL: CANTO 90° - COM PERFIL FC 42

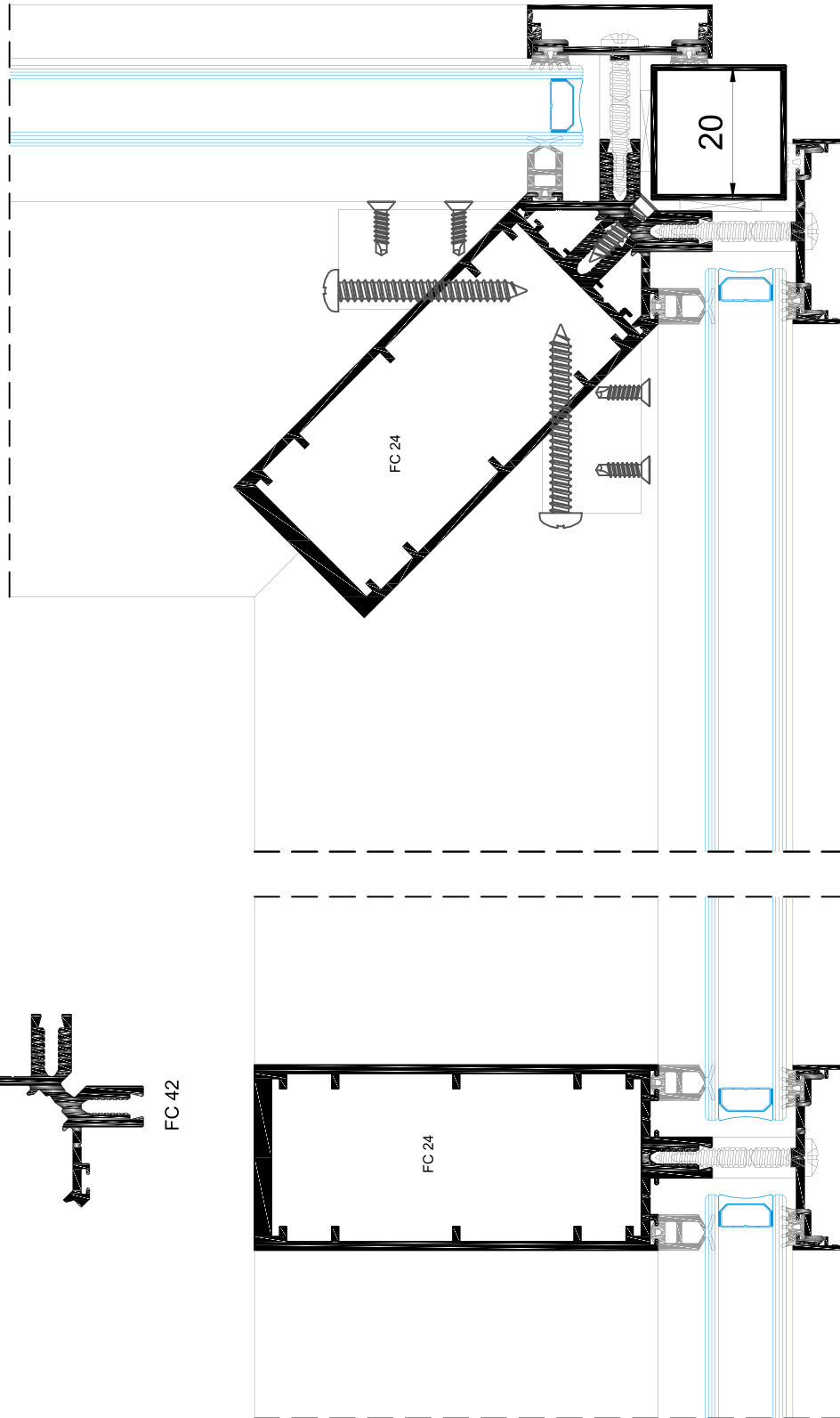
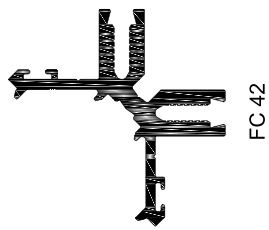

ESCALA 1:2

FC HORIZONTE COM JANELA PROJETANTE OCULTA: SISTEMA CONVENCIONAL COM VIDRO DUPLO DE 24mm ESPESSURA TOTAL

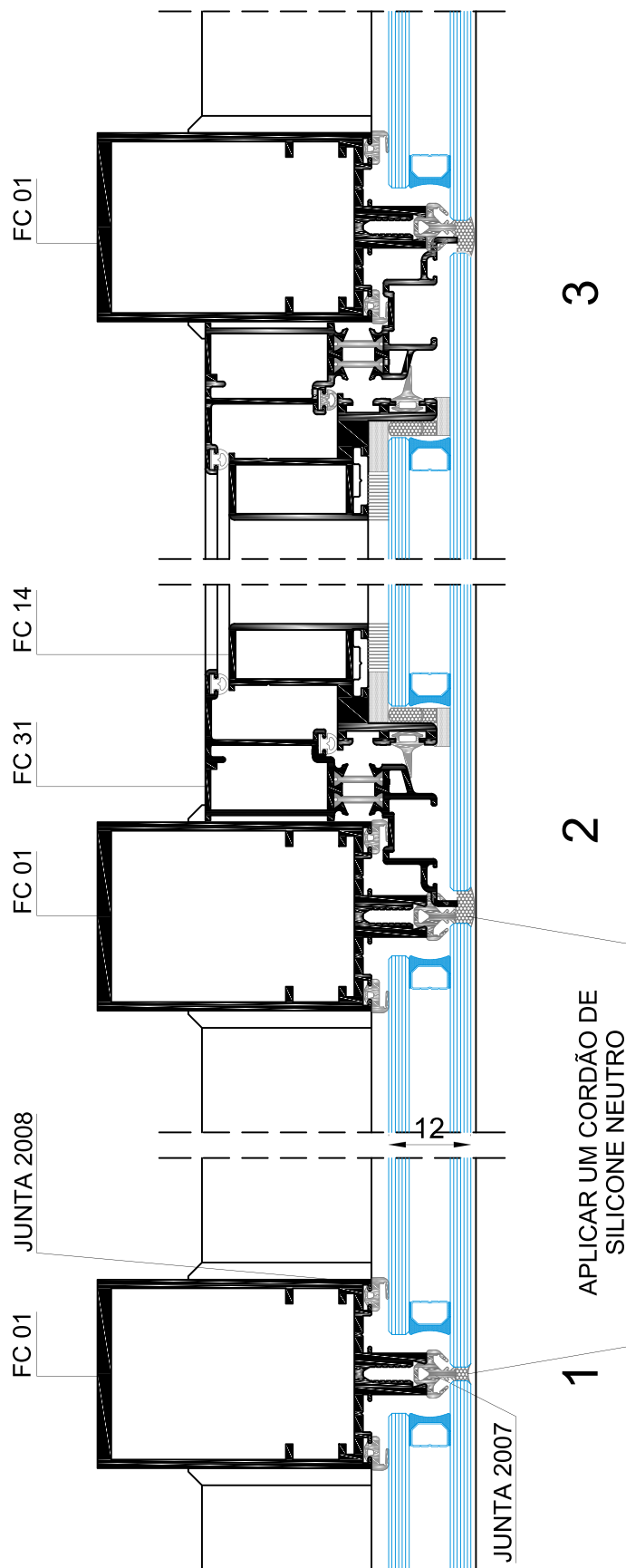
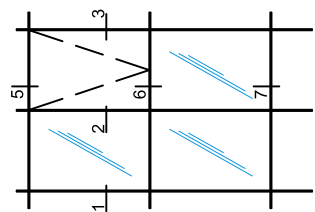

VIDRO (6mm+cx12+6mm) com decalagem

O Grupo Sosoares recomenda que o vidro exterior de 6mm seja temperado com tratamento térmico HST

ESCALA 1:2

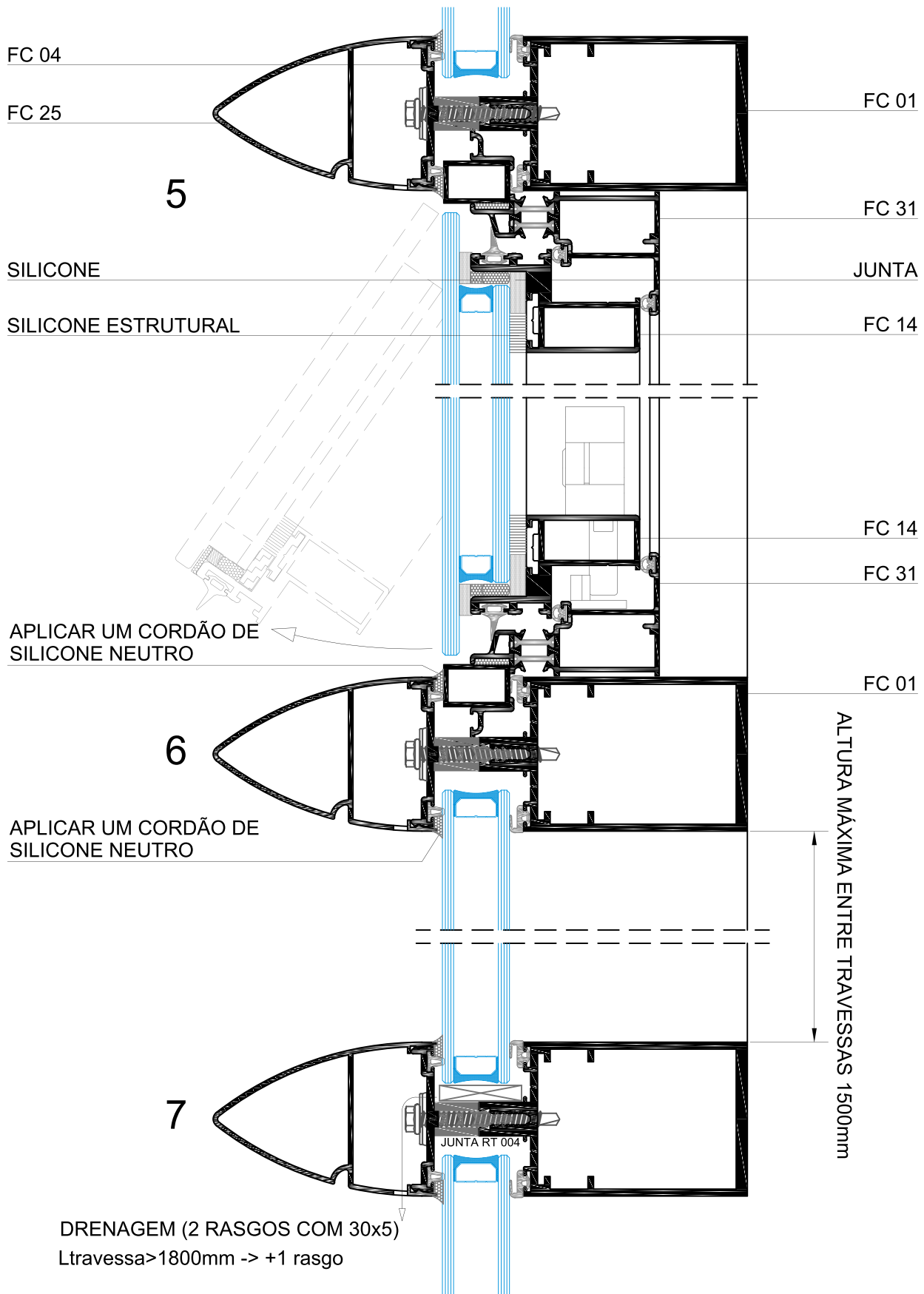

SÉRIE FC

FC HORIZONTE

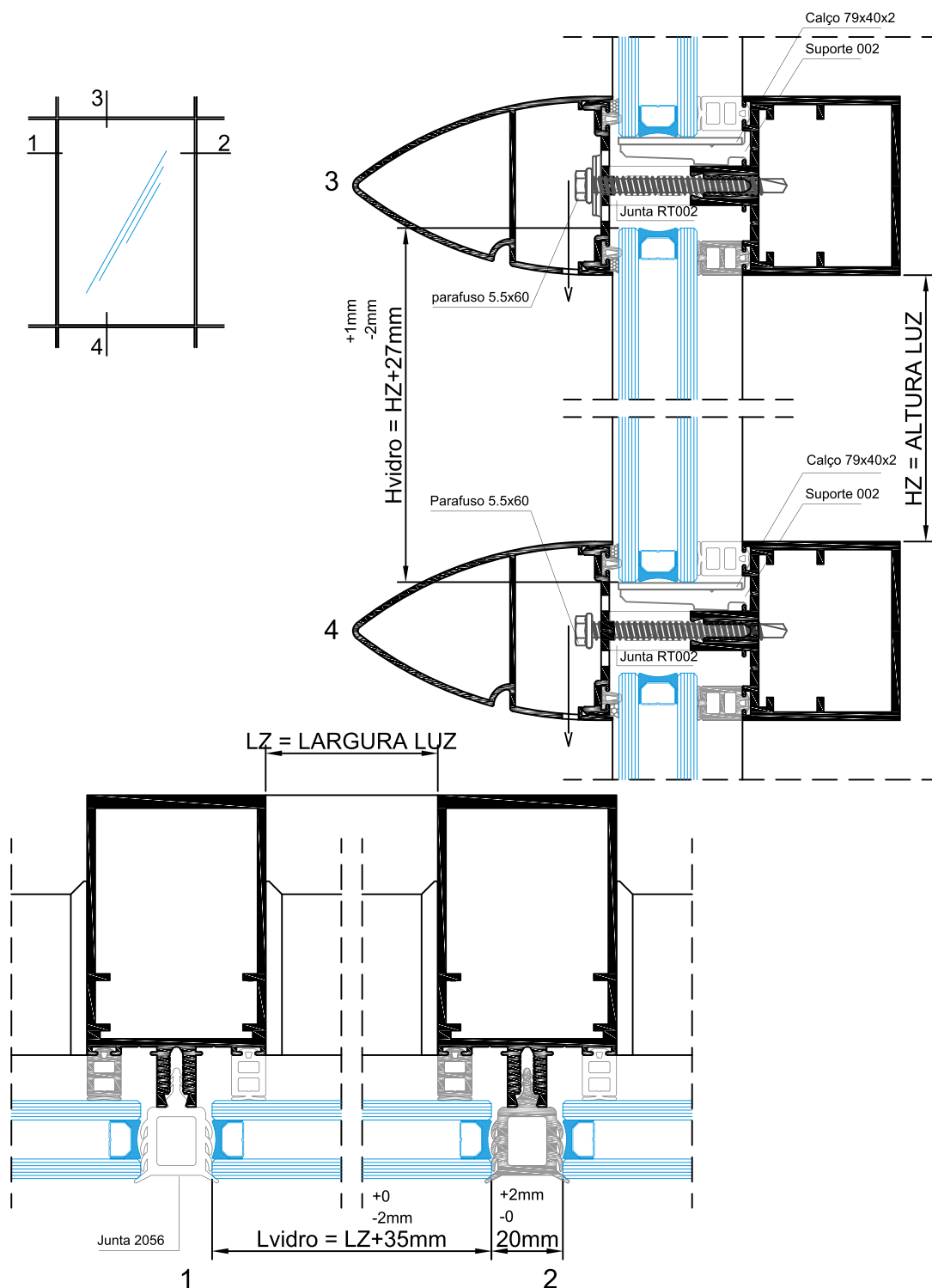

As dimensões dos vidros são essenciais para um bom desempenho da nova fachada FC HORIZONTE.

ESCALA 1:2

FC SEMI-OCULTA COM ESTORE INTERIOR DE VIDRO

Pormenor:

- montante e travessas com FC 02
- aplicação de estore no interior da câmara (22mm) do vidro duplo

Recomendações:

- vidro duplo com espessura máxima de 32mm.
- estore interior com motor elétrico accionado por interruptor ou comando à distância
- a folha projetante não deve ultrapassar as medidas indicadas no nosso catálogo, de forma a garantir um bom desempenho

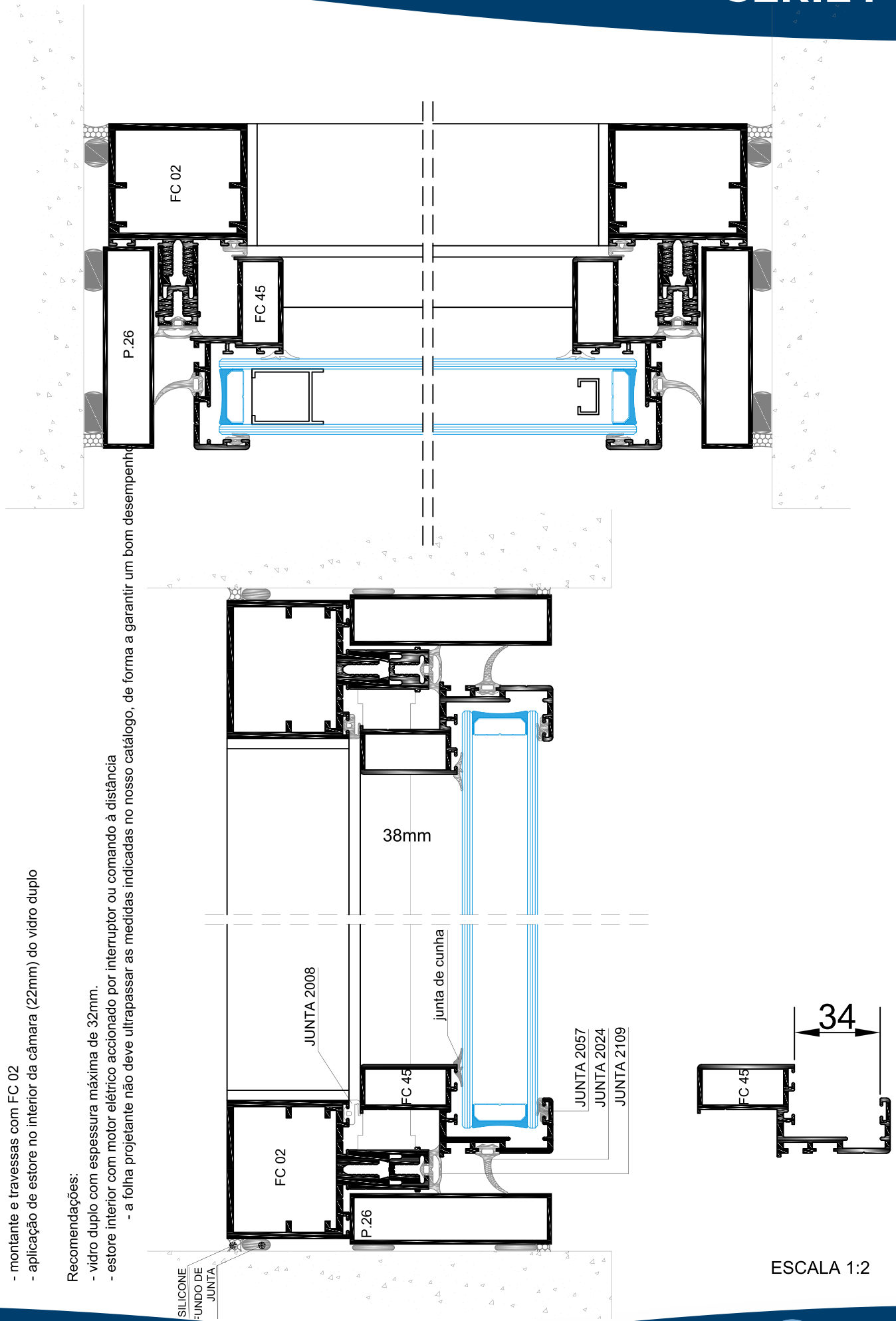

ESCALA 1:2

FACHADA SEMI-OCULTA COM JANELA PROJETANTE COM O PERFIL FC 35

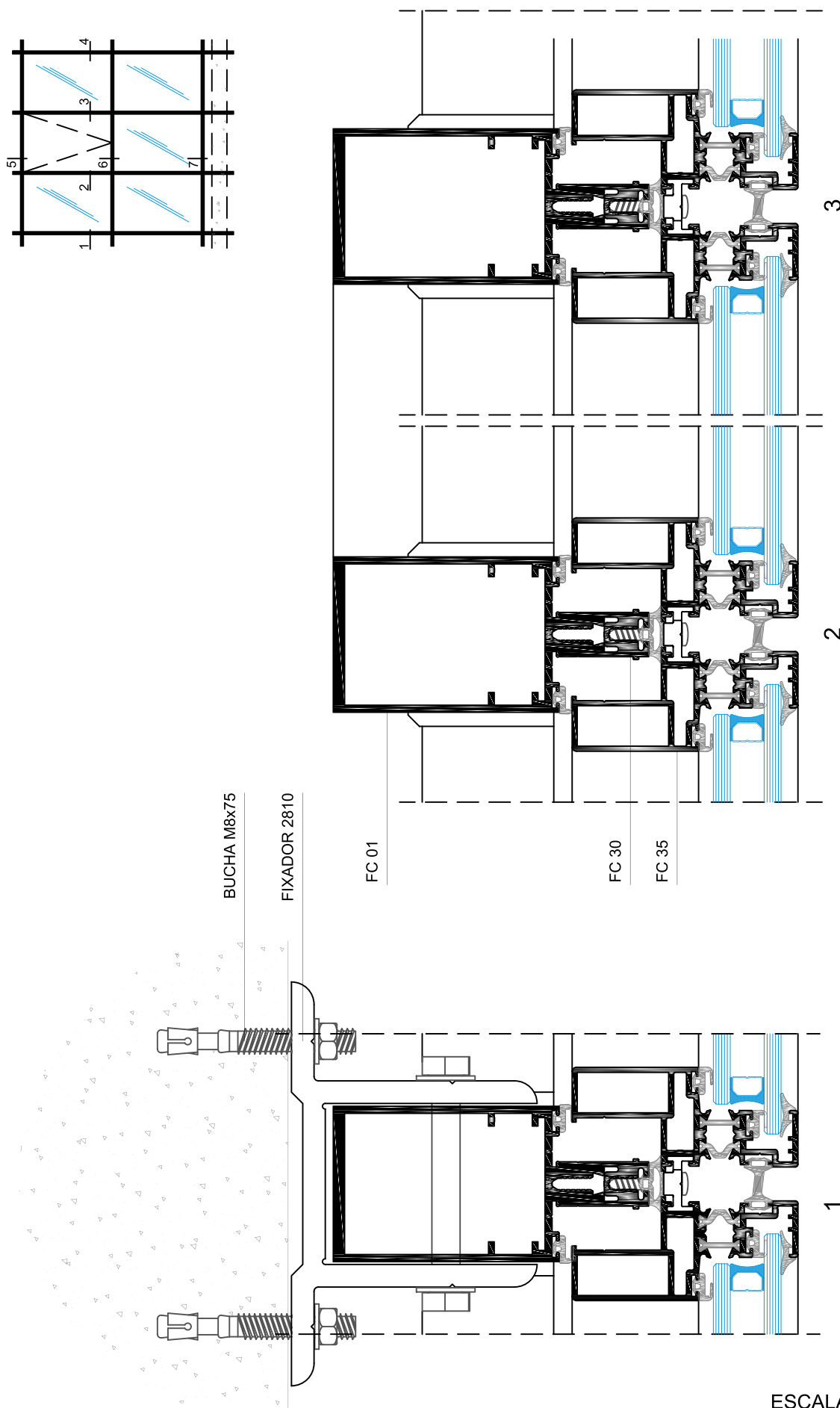

ESCALA 1:2

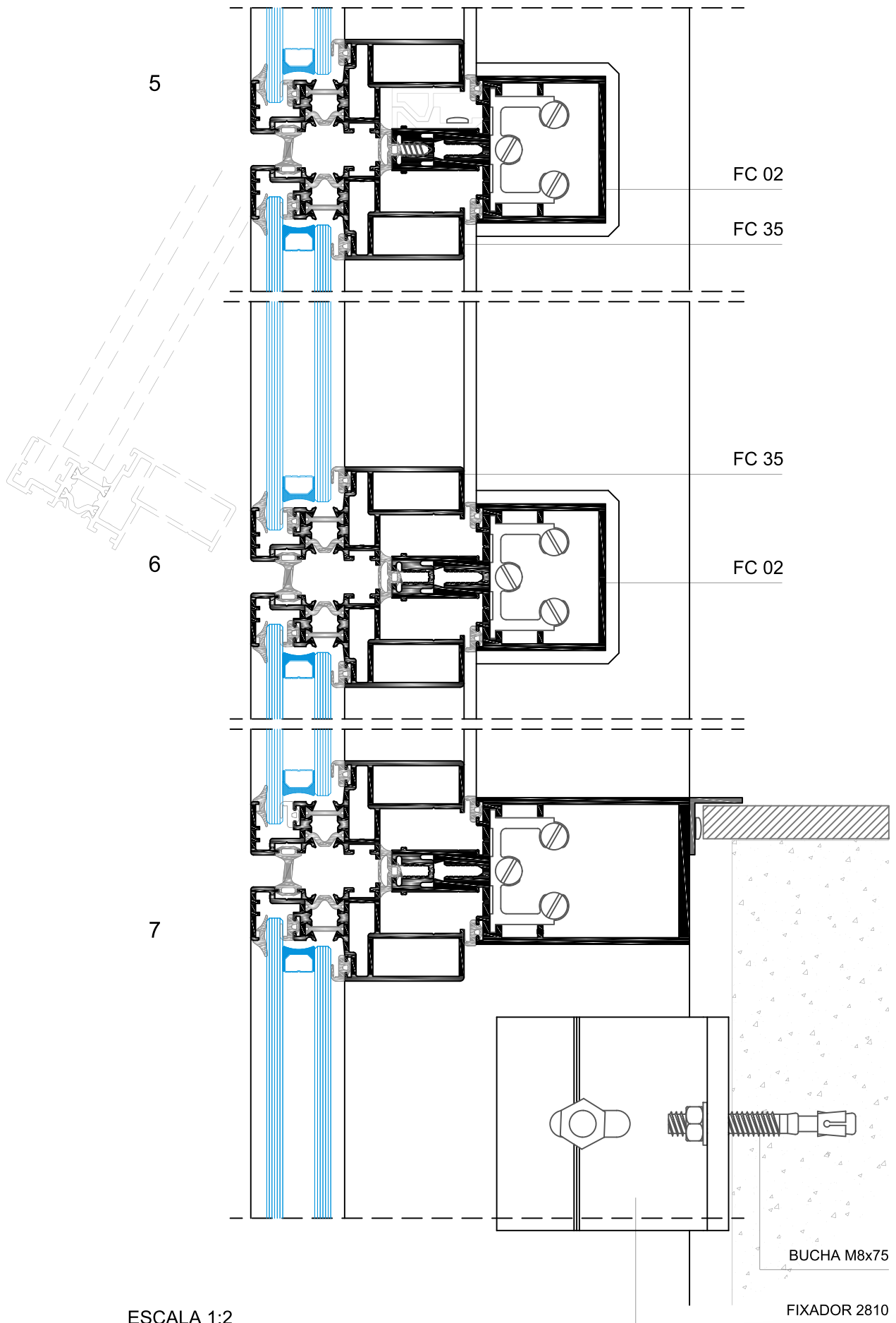

ESCALA 1:2

PORMENOR DE FACHADA SEMI-OCULTA - MONTANTE
PORMENOR DE FACHADA SEMI-OCULTA - TRAVESSA

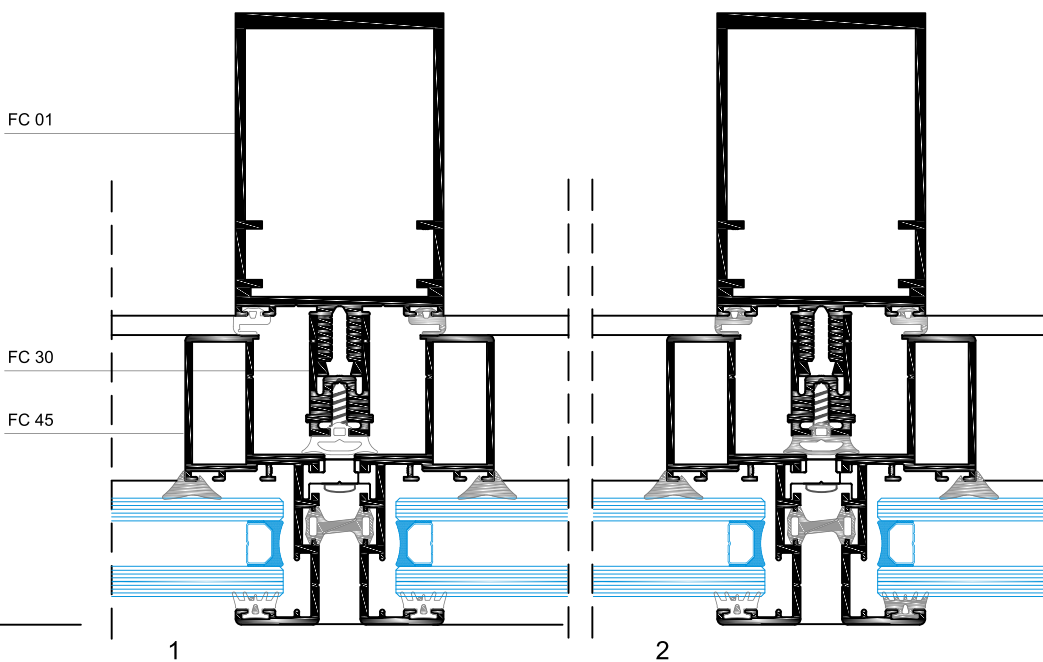
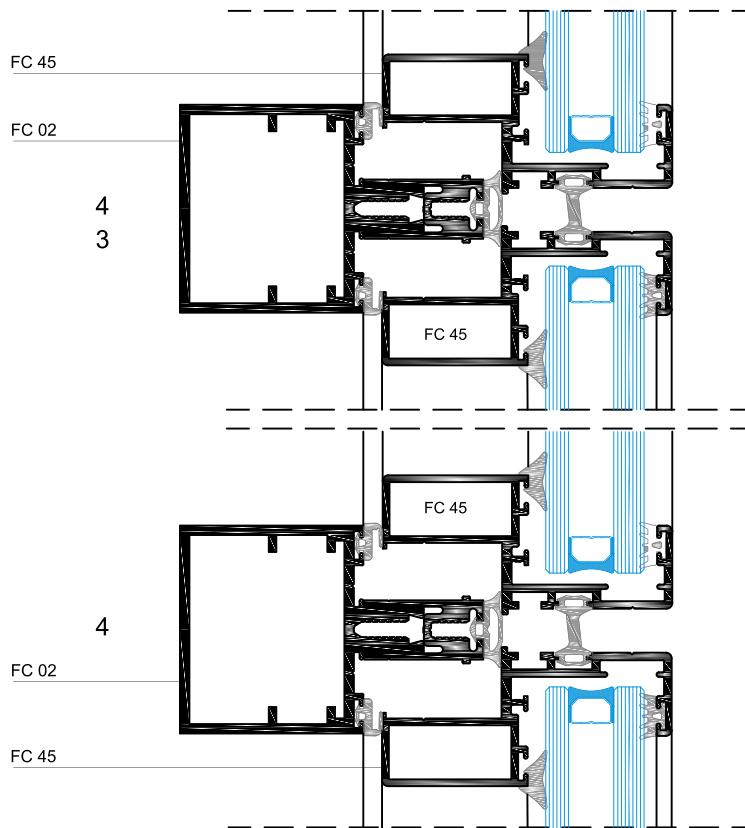
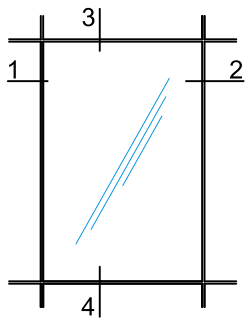

ESCALA 1:2

FACHADA SEMI-OCULTA: CANTO 90°

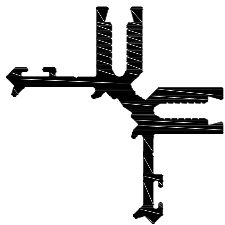

FC 42

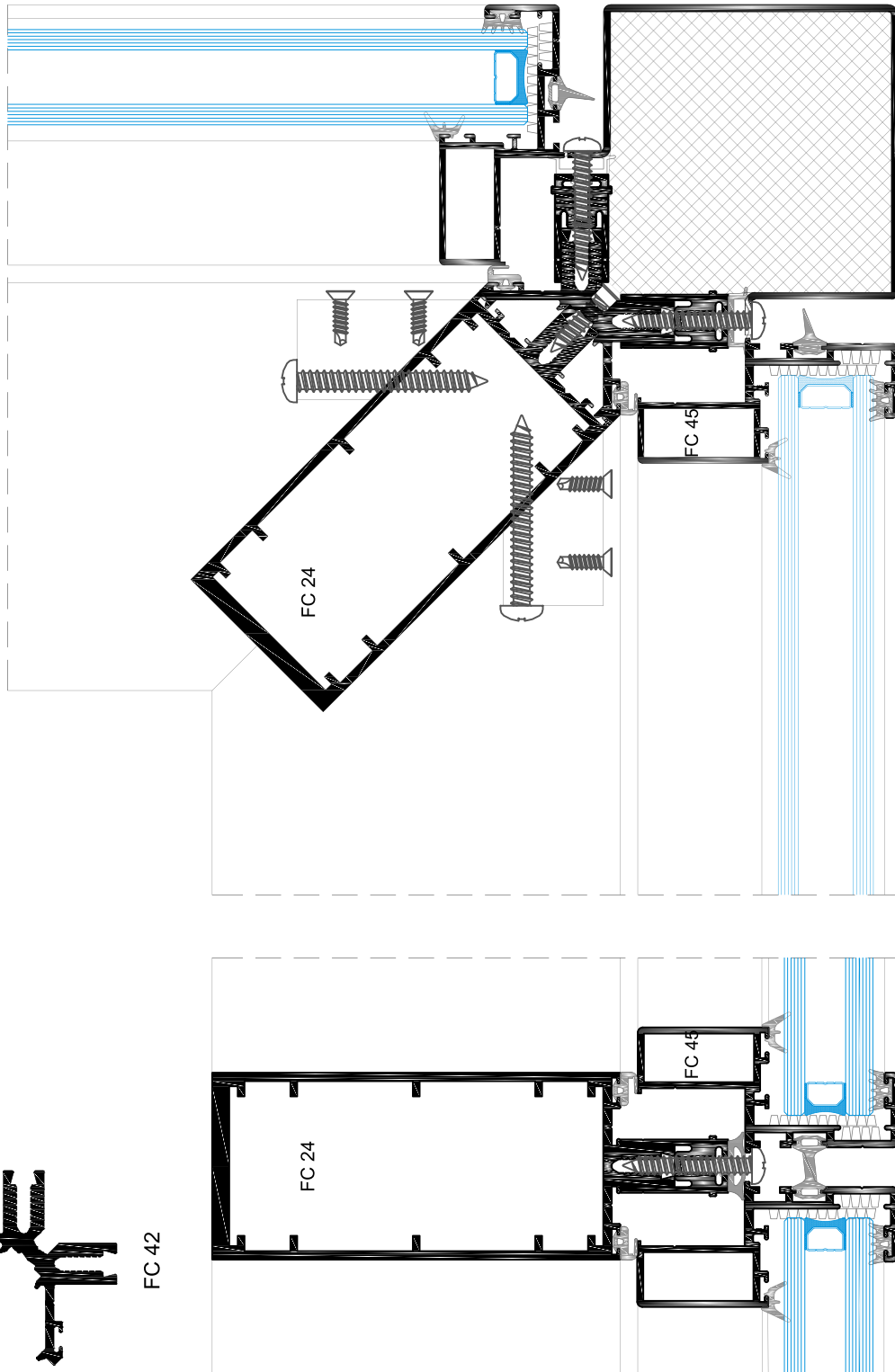

ESCAI A 1:2

FACHADA OCULTA COM JANELA PROJETANTE

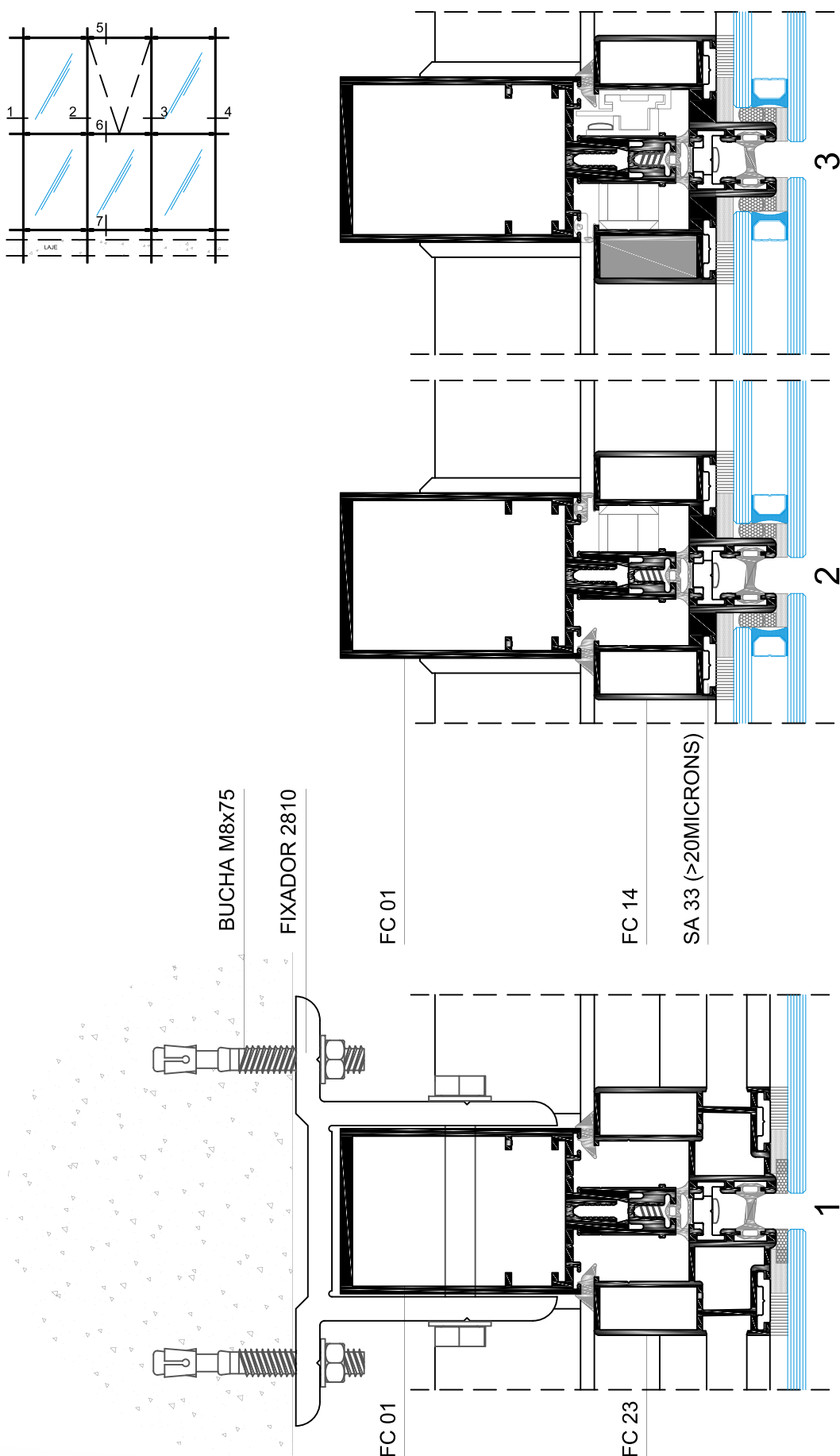
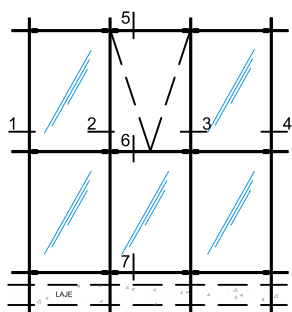

ESCALA 1:2

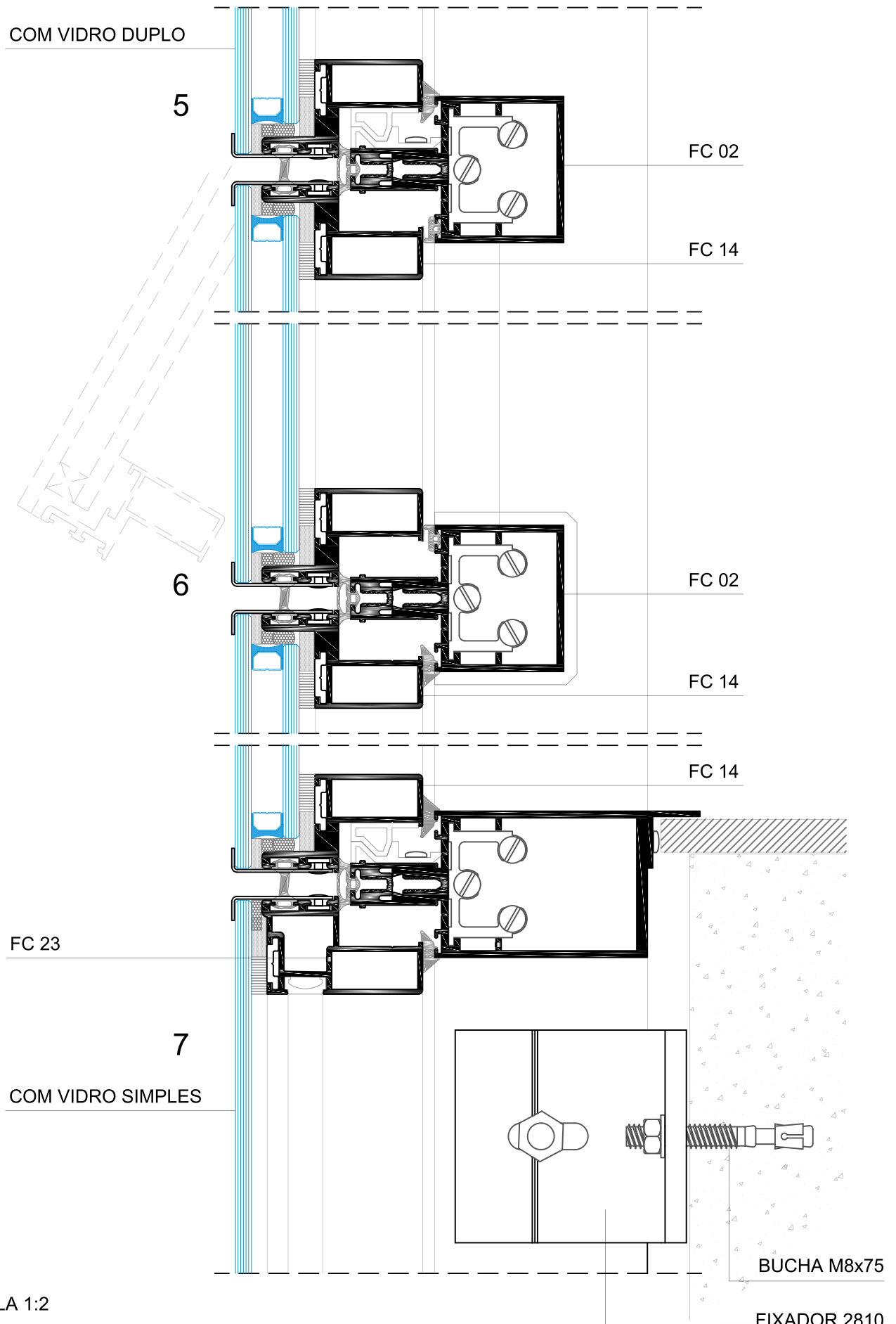

ESCALA 1:2

REMATE À PAREDE COM PERFIL FC 28

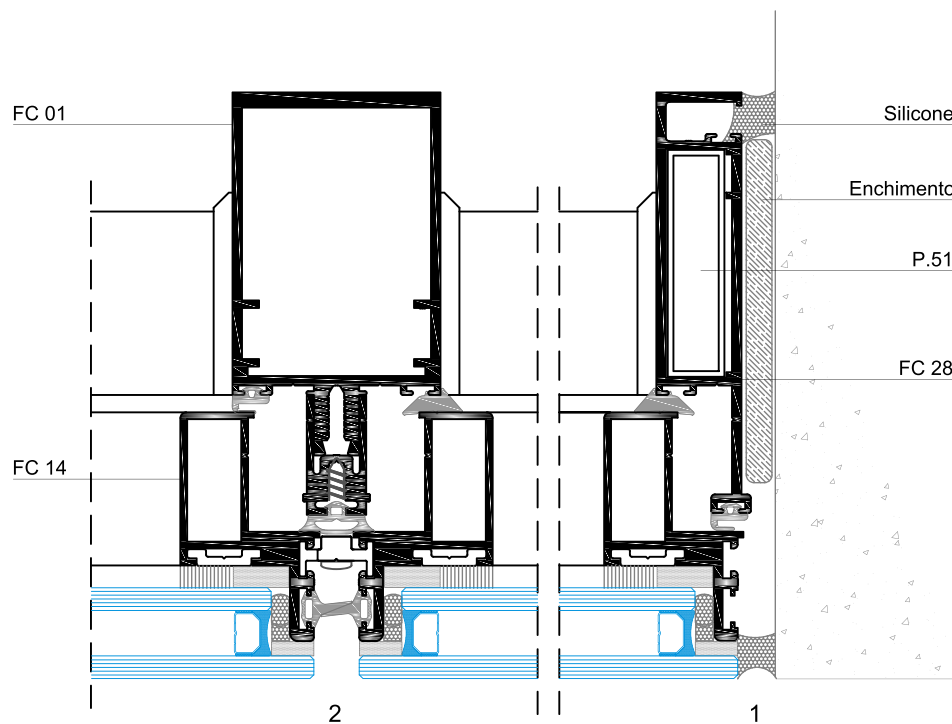
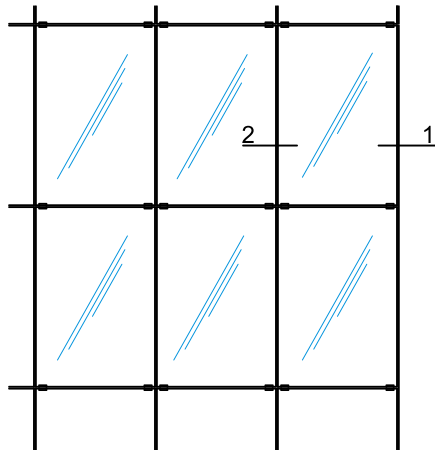

OS PORMENORES MENCIONADOS SÃO A TÍTULO INFORMATIVO.
PARA PROJETOS ESPECÍFICOS CONTATAR O DEPARTAMENTO TÉCNICO.

ESCAI A 1:2

REMATE À PAREDE COM PERFIL FC 38

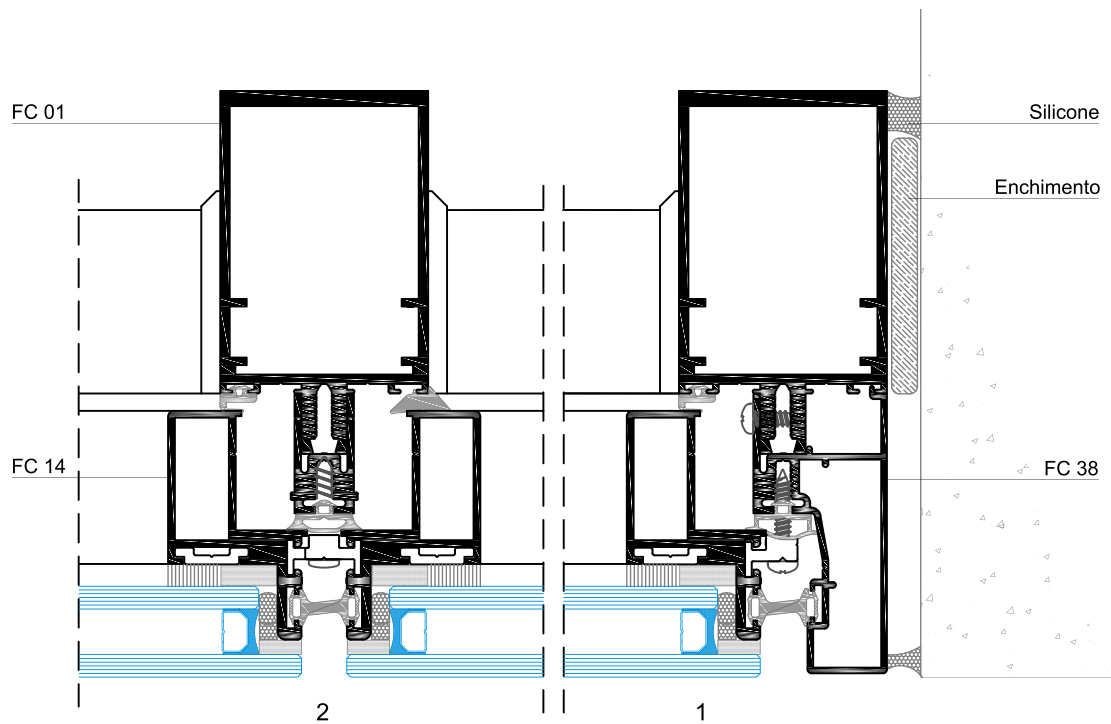
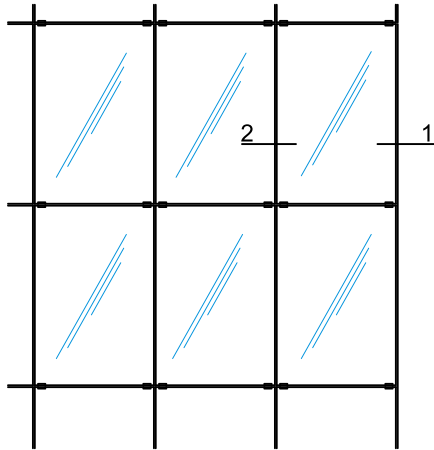

OS PORMENORES MENCIONADOS SÃO A TÍTULO INFORMATIVO.
PARA PROJETOS ESPECÍFICOS CONTATAR O DEPARTAMENTO TÉCNICO.

REMATE À PAREDE COM PERFIL FC 82 ou FC 83 - SOLUÇÃO 90° - CORTE HORIZONTAL

FC 83

Fixador 2813 - serrafiado

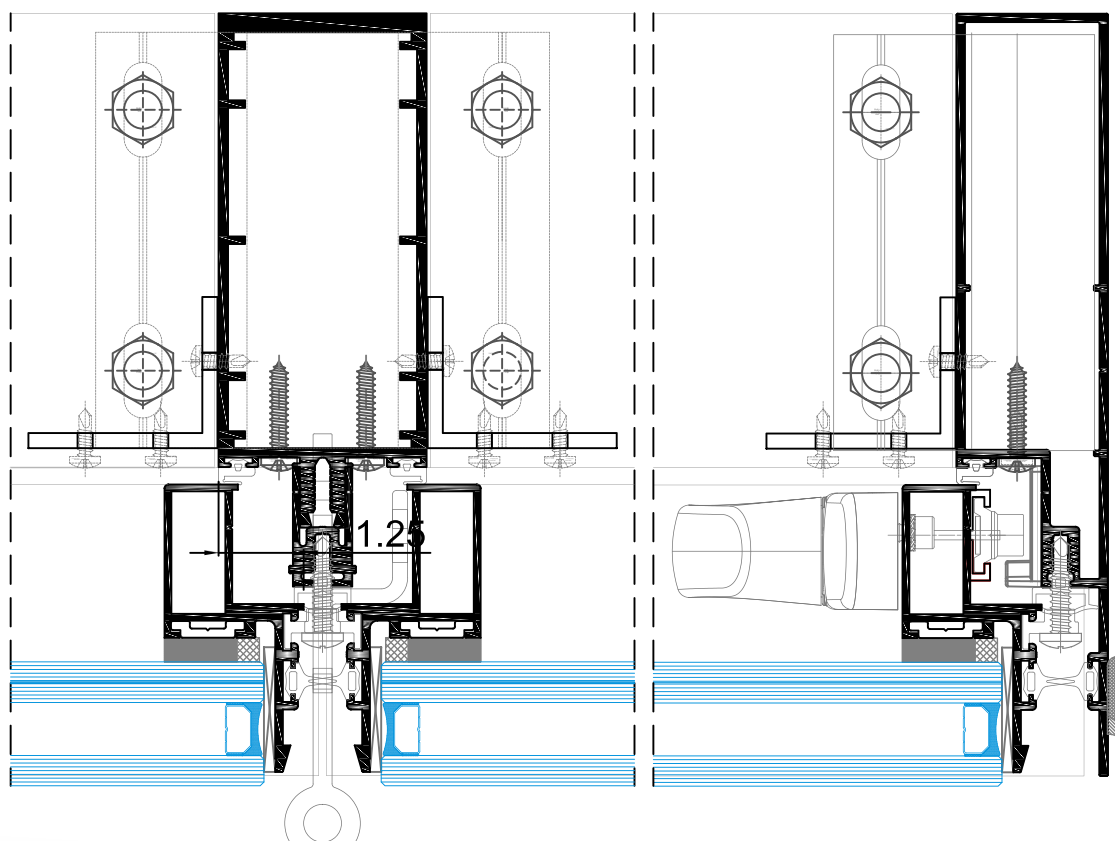
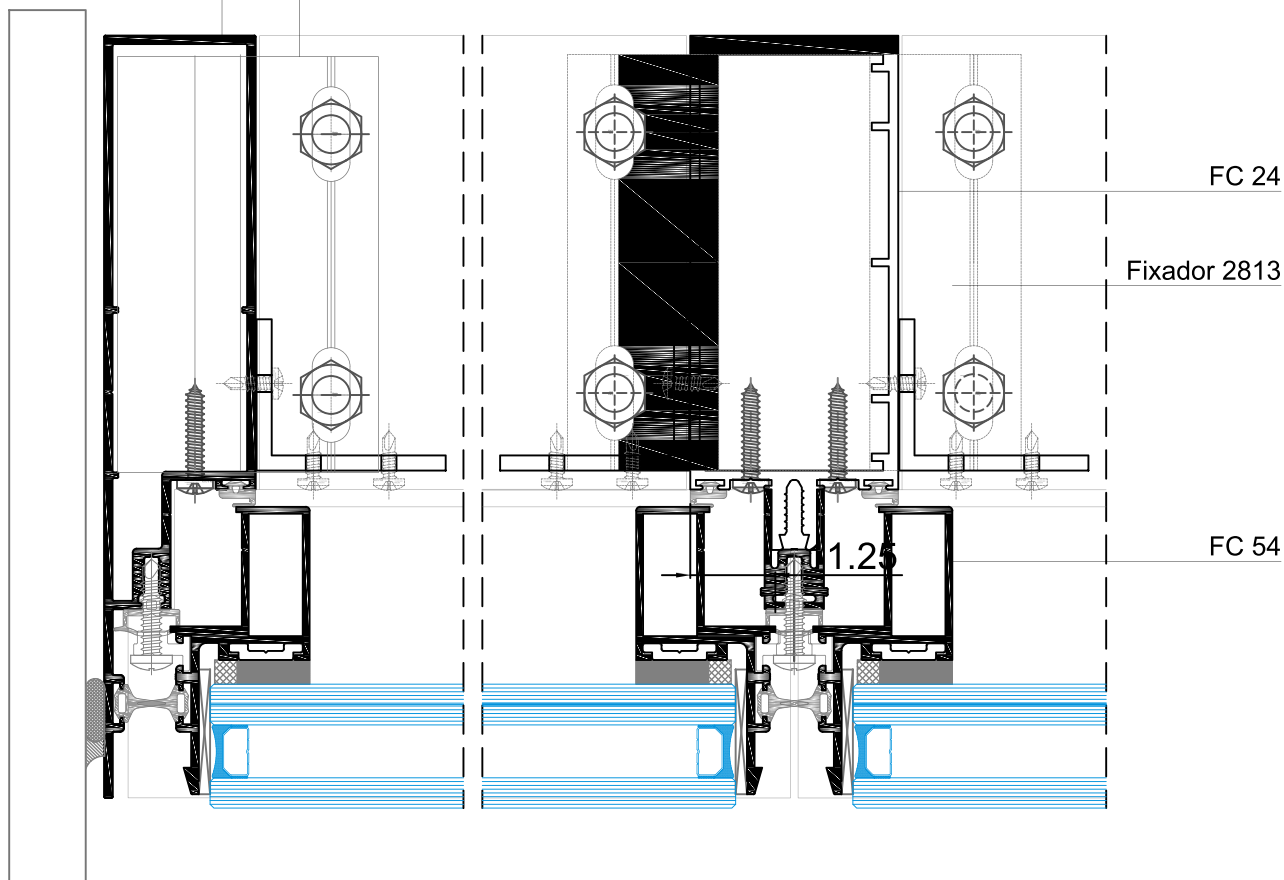

REMATE À PAREDE COM PERFIL FC 82 ou FC 83 - SOLUÇÃO 90° - CORTE VERTICAL

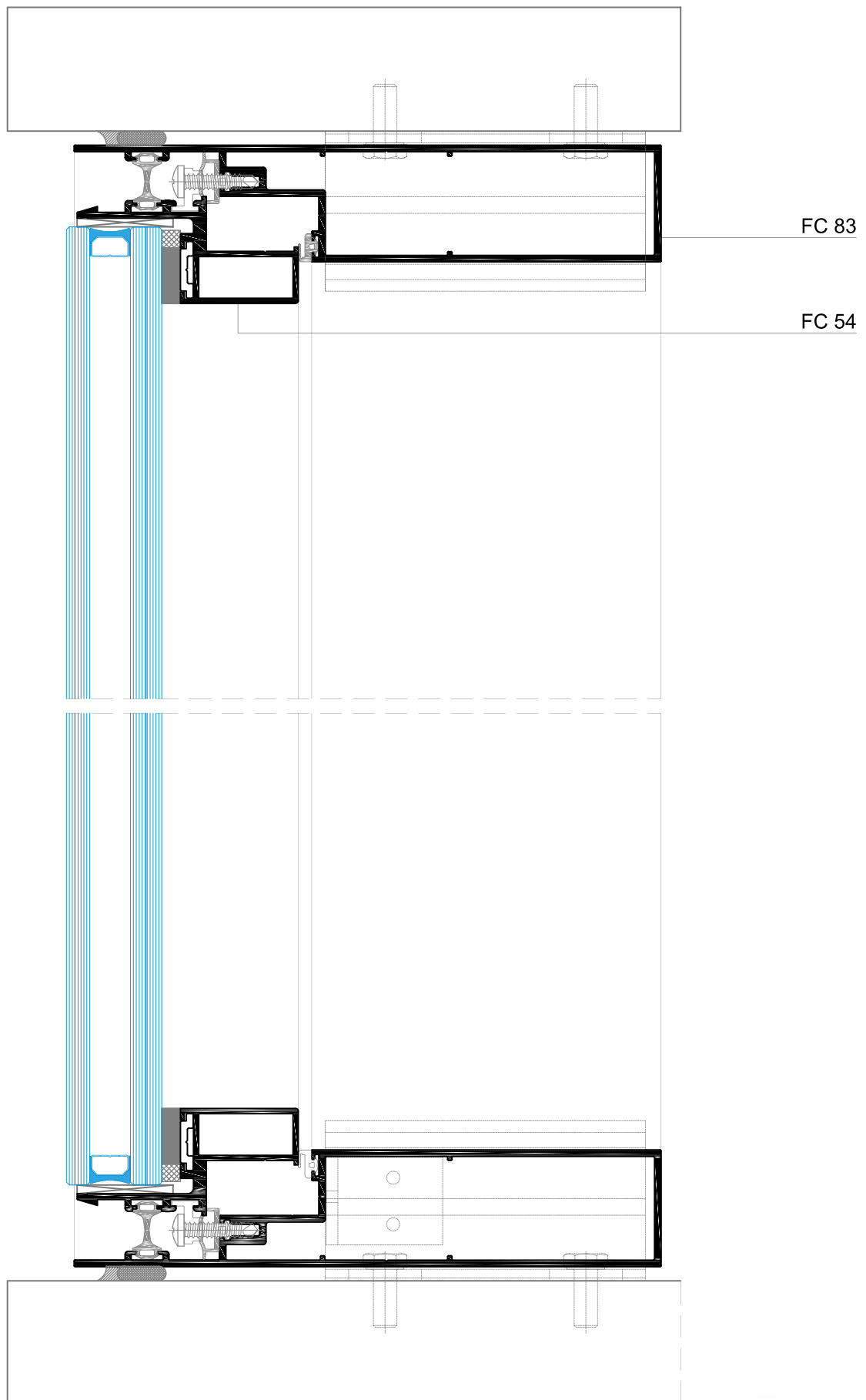

REMATE À PAREDE COM PERFIL FC 82 ou FC 83 - SOLUÇÃO 45° - CORTE HORIZONTAL

FC 83

União UT2807

FC 24

FC 54

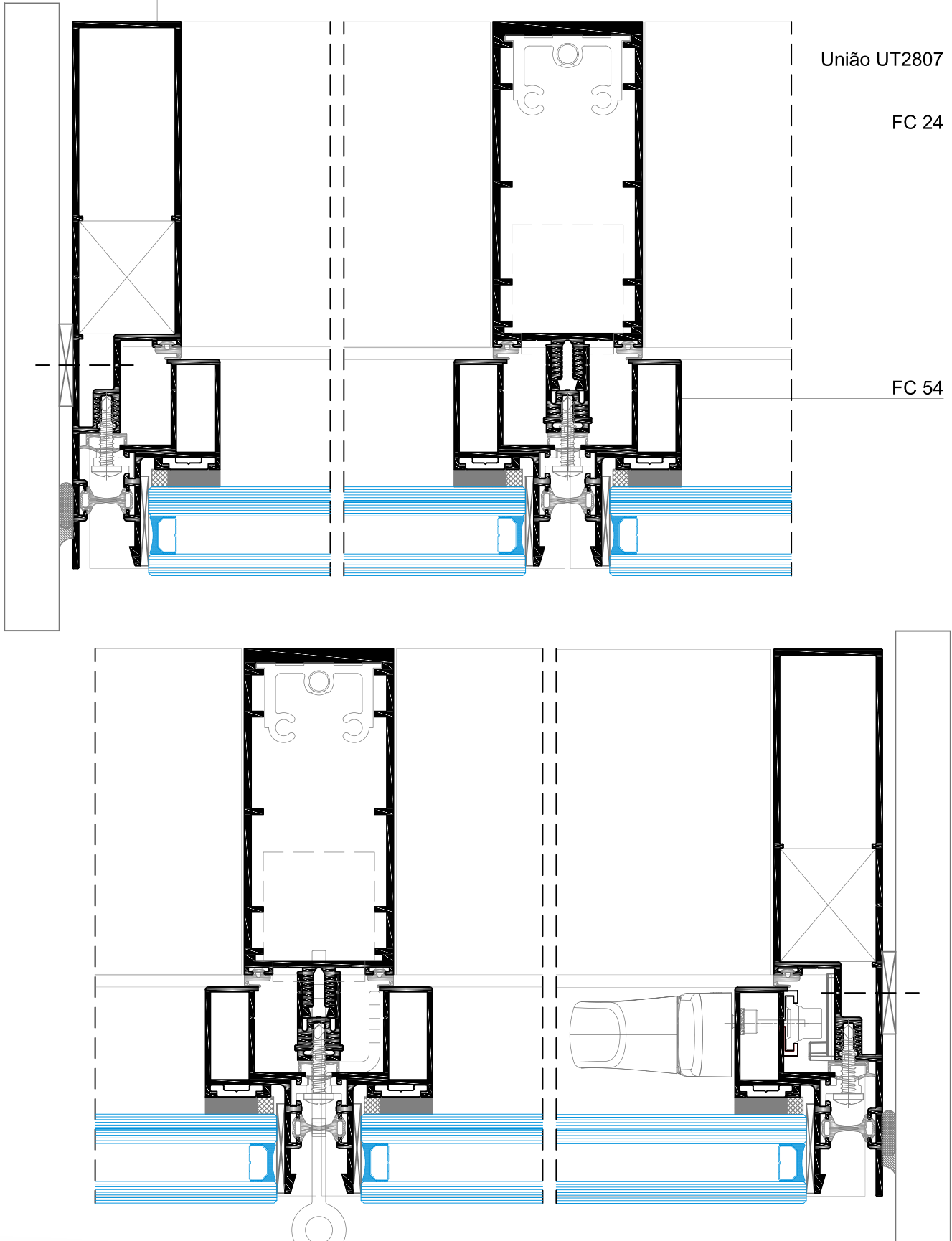

REMATE À PAREDE COM PERFIL FC 82 ou FC 83 - SOLUÇÃO 45° - CORTE VERTICAL

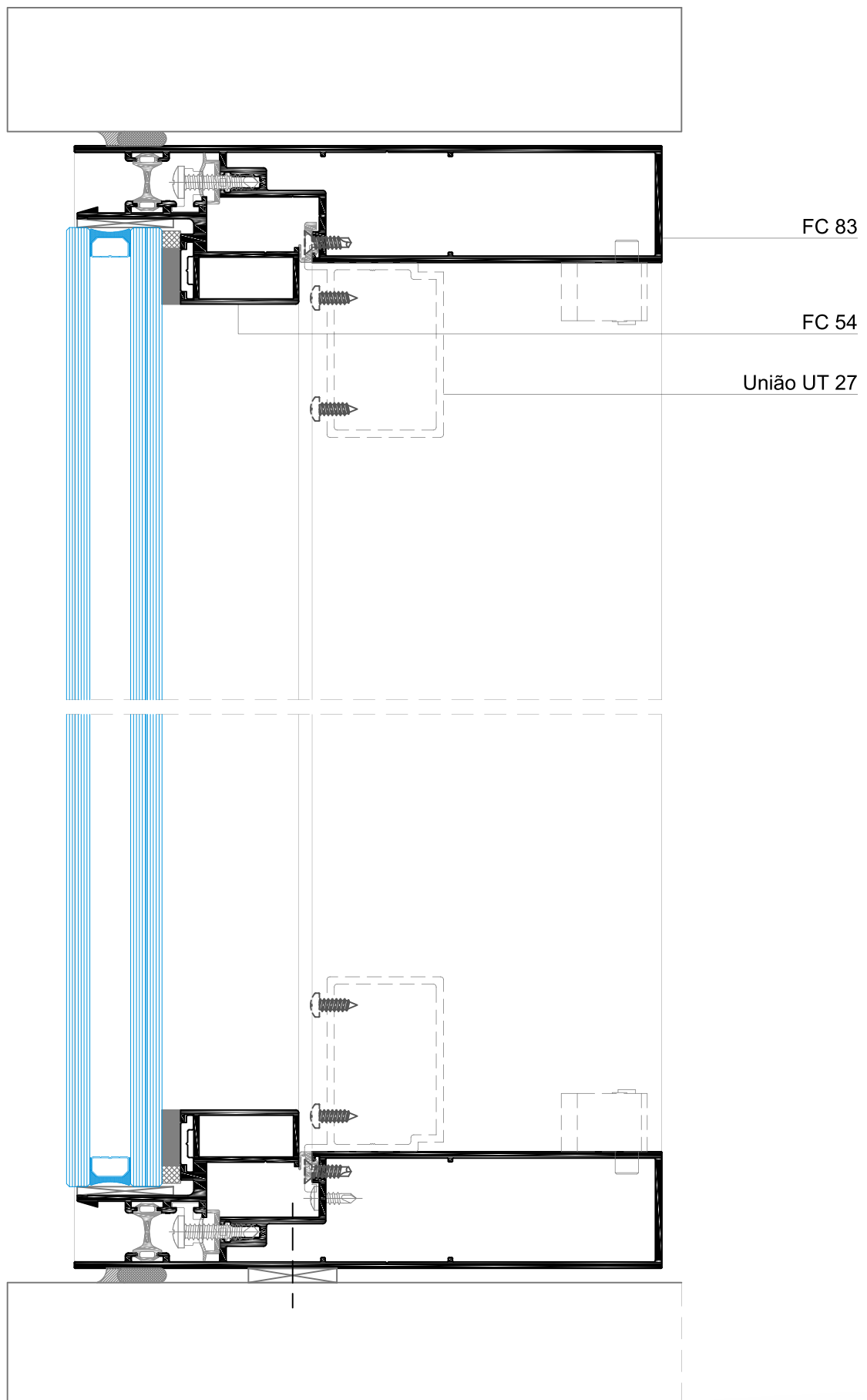

FACHADA OCULTA: CANTO A 90°

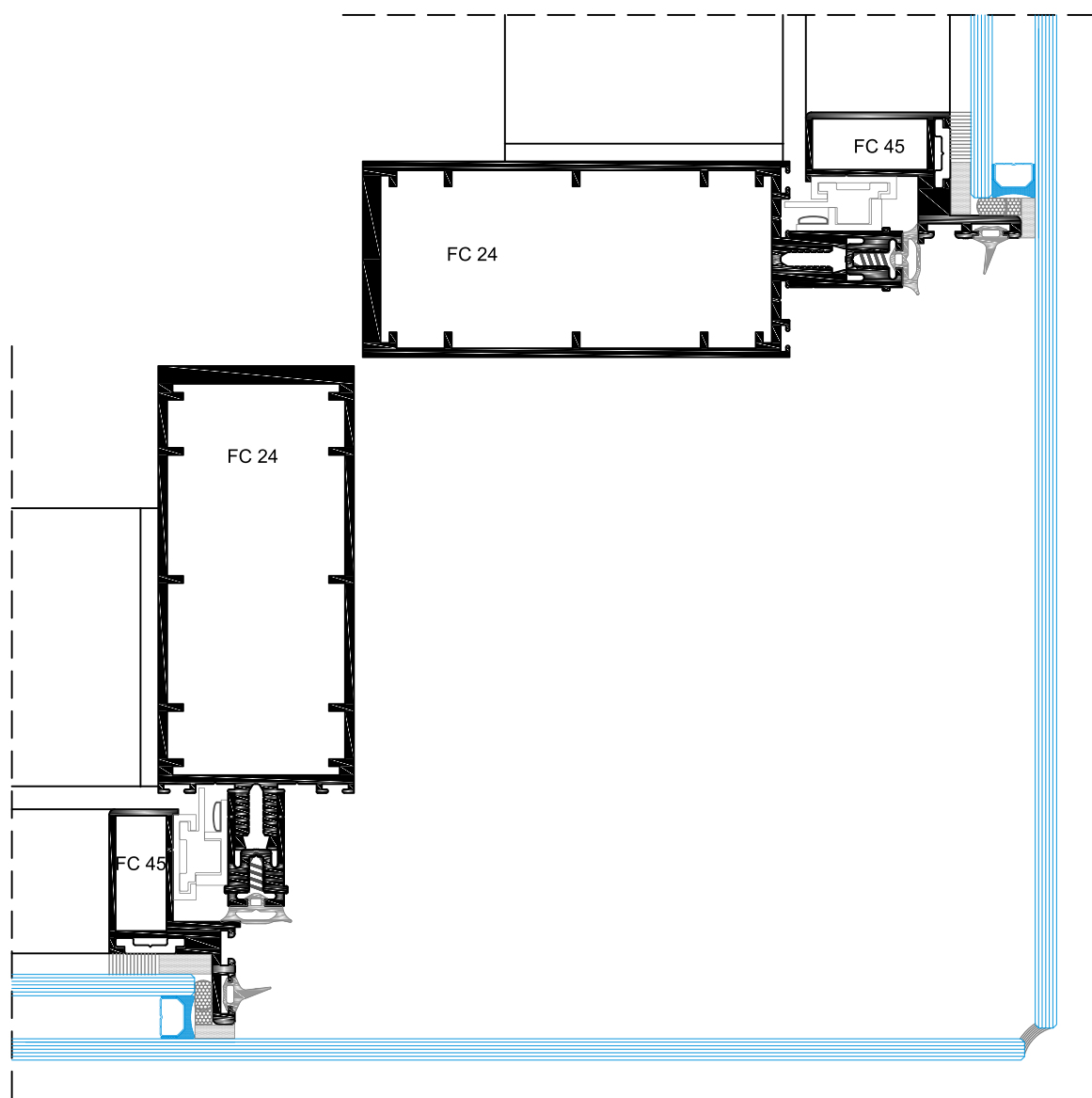

FACHADA OCULTA: CANTO A 90°

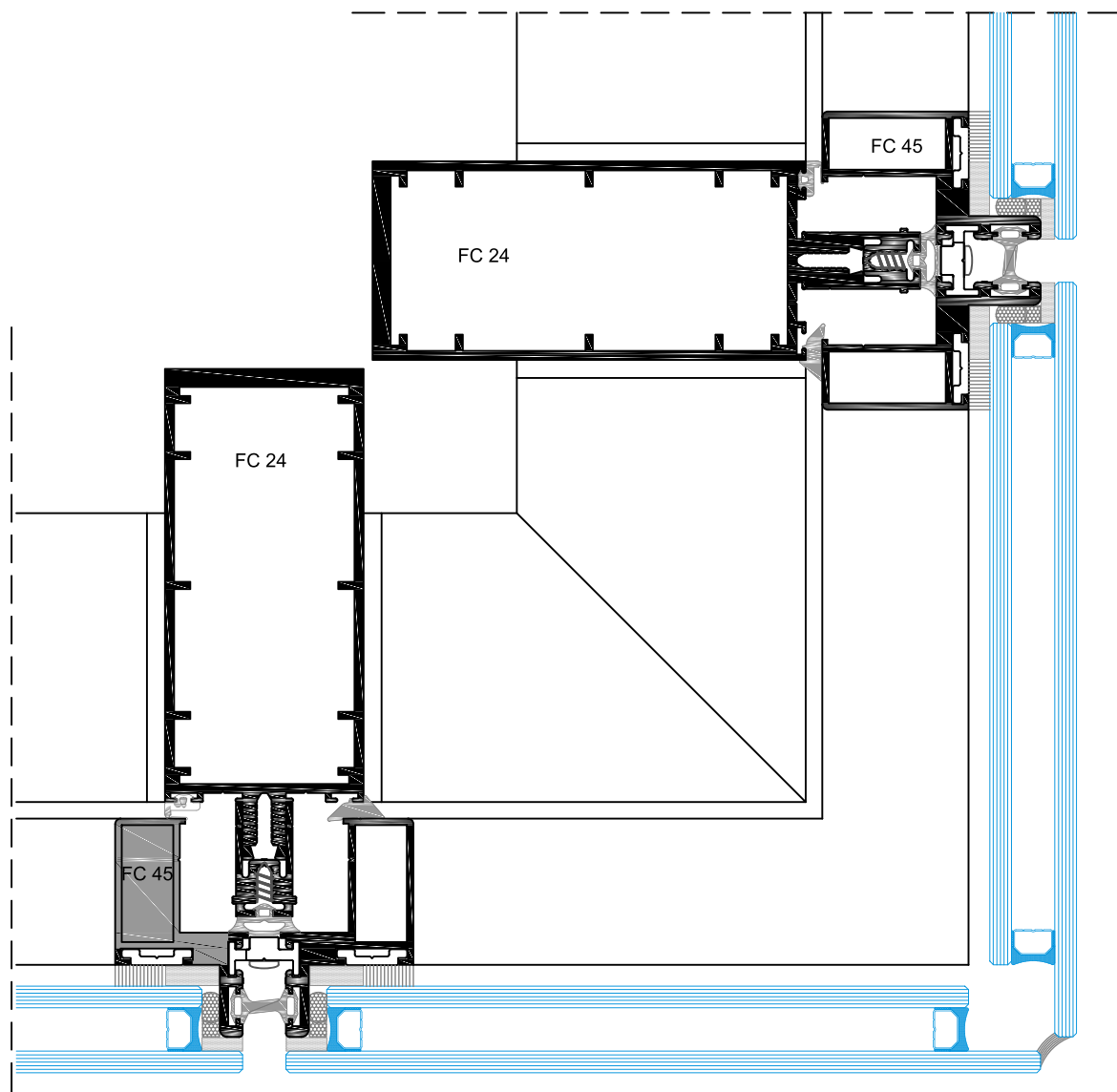

SÉRIE FC

FACHADA OCULTA - COM O PERFIL FC54

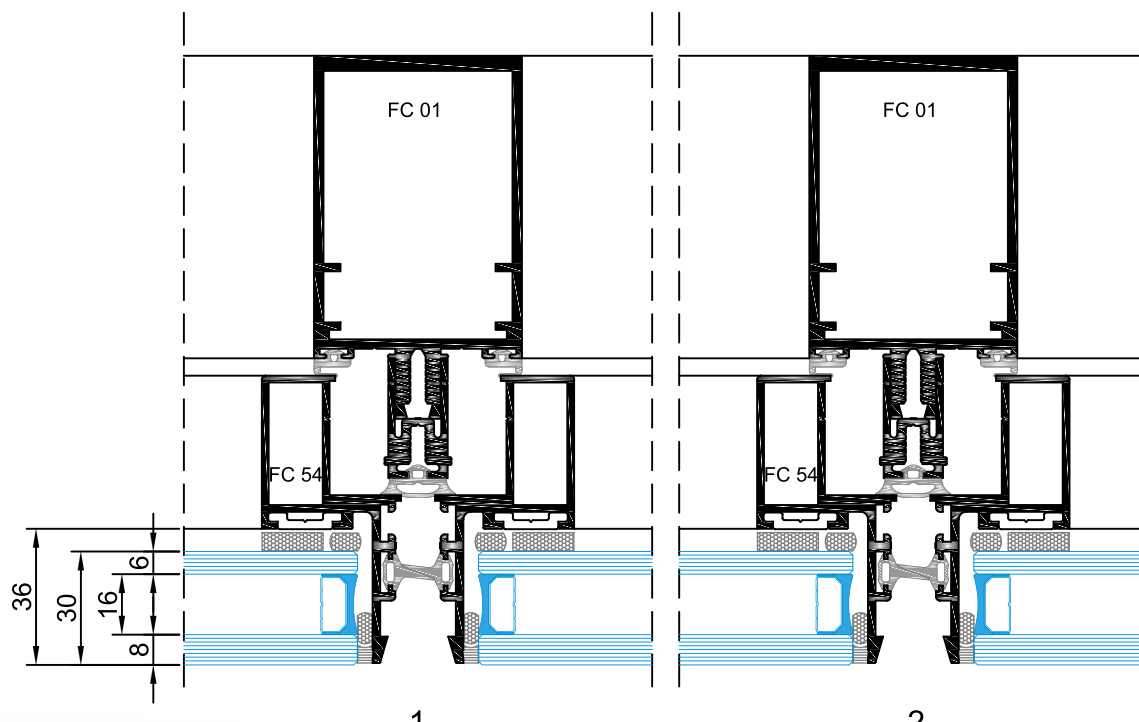
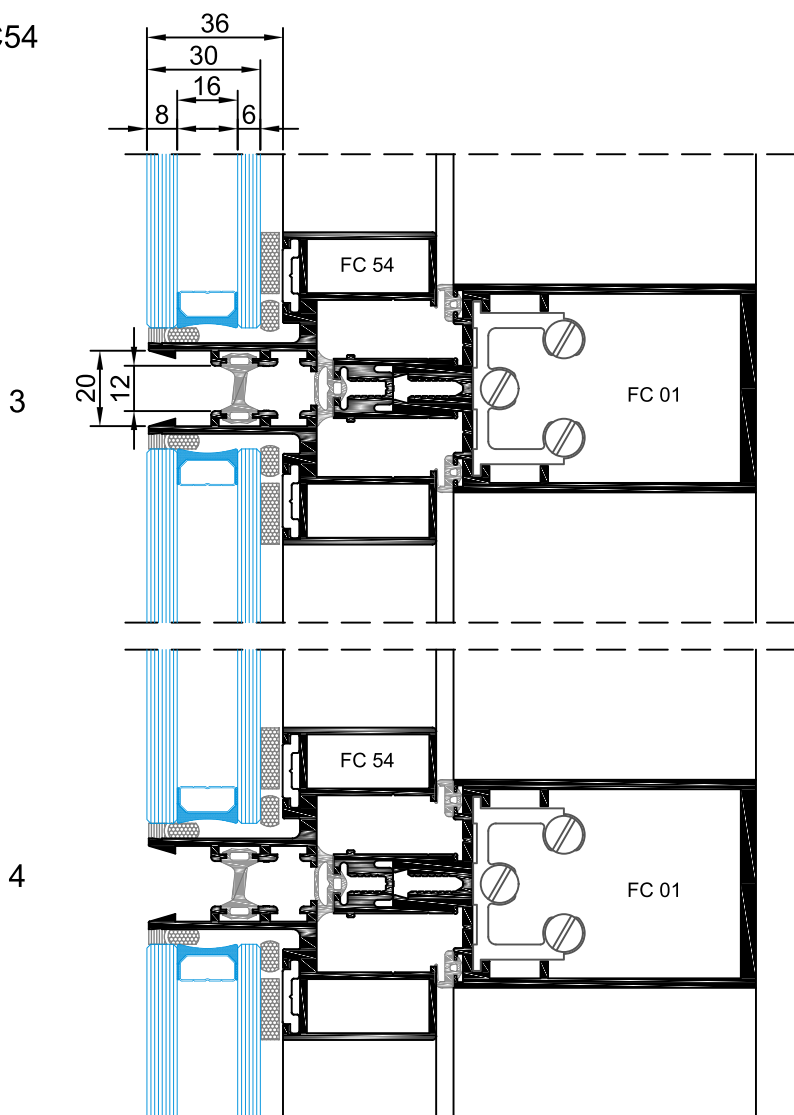
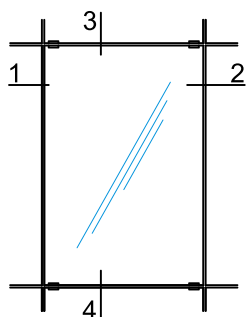

FACHADA OCULTA - COM O PERFIL FC54 E APLICAÇÃO DA JUNTA 2156 (A APLICAÇÃO DA JUNTA 2156 É OPCIONAL)

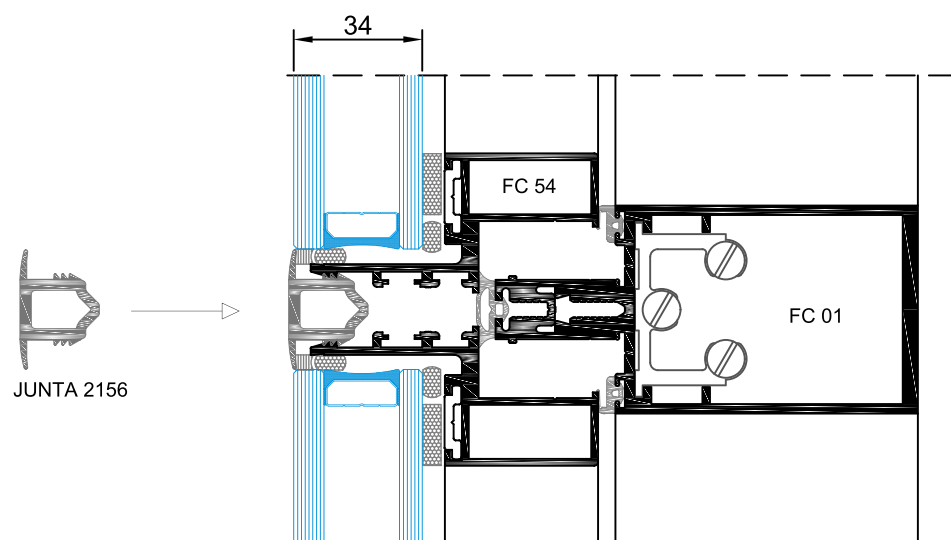
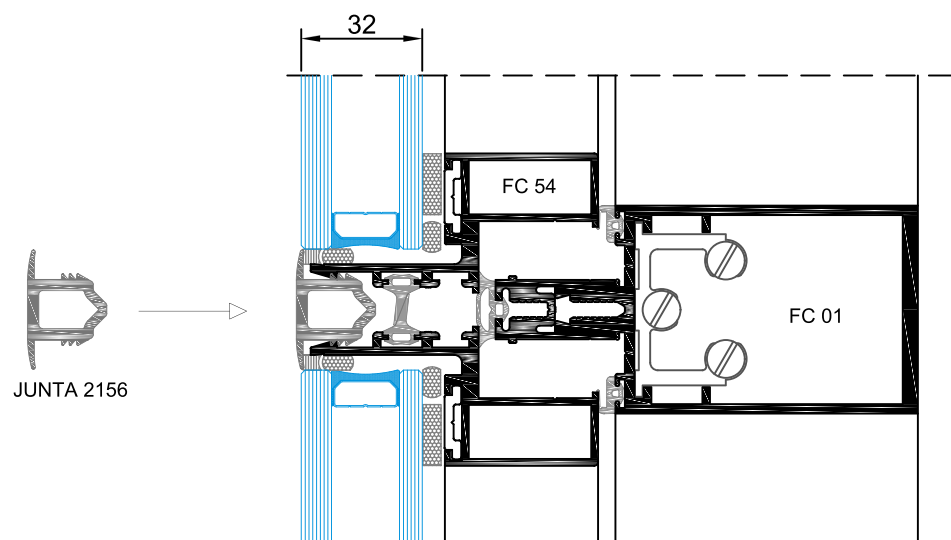
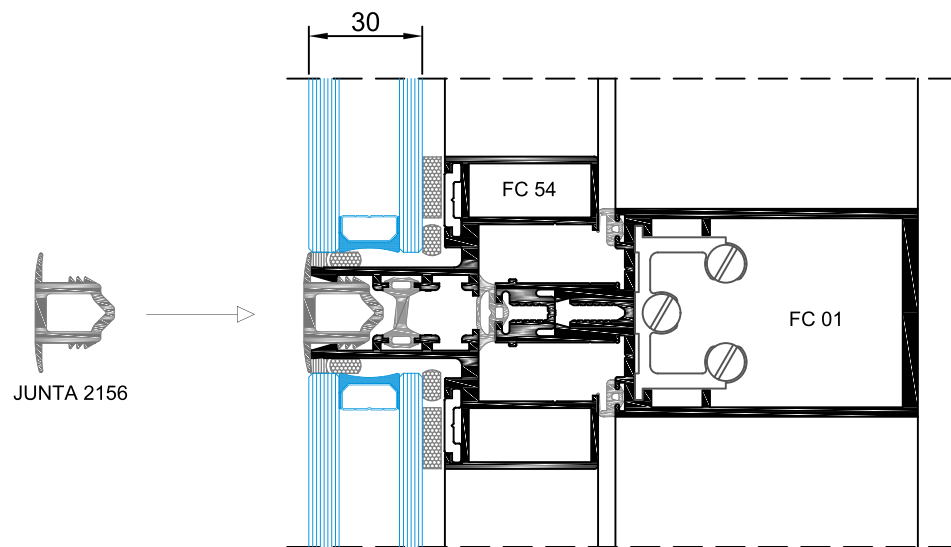

JANELA PROJETANTE COM O PERFL FC 64

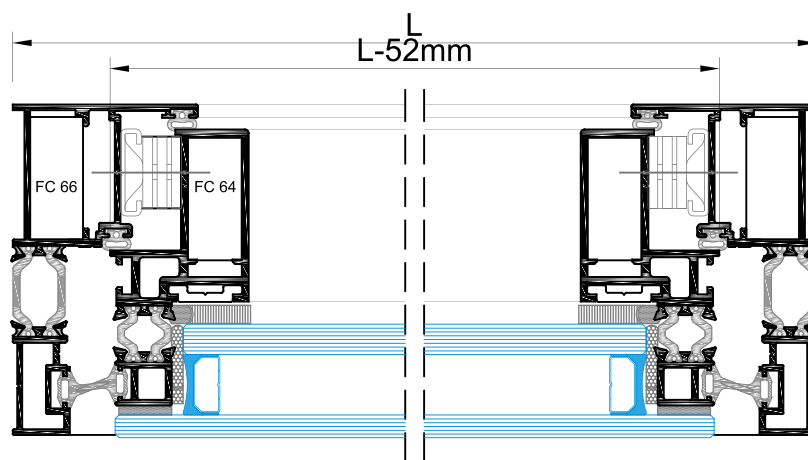
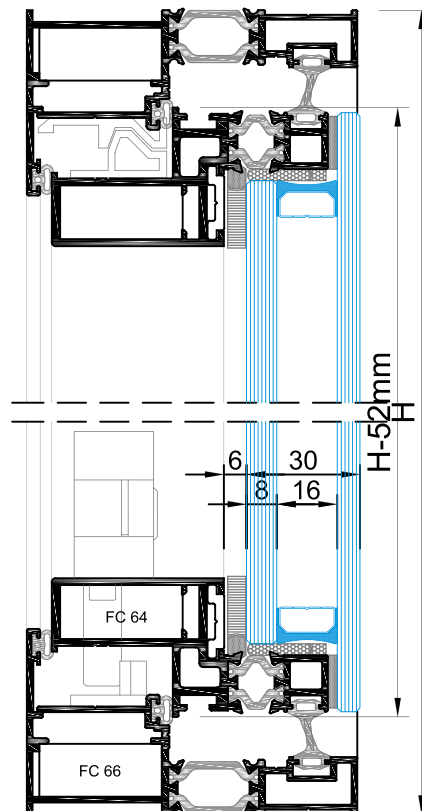
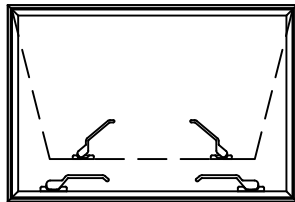

JANELA PROJETANTE
COM OS PERFIS FC 65 e FC 66

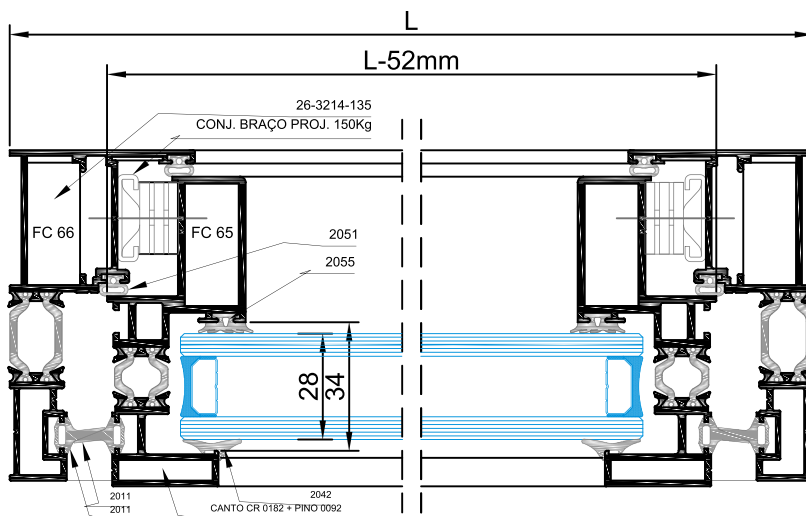
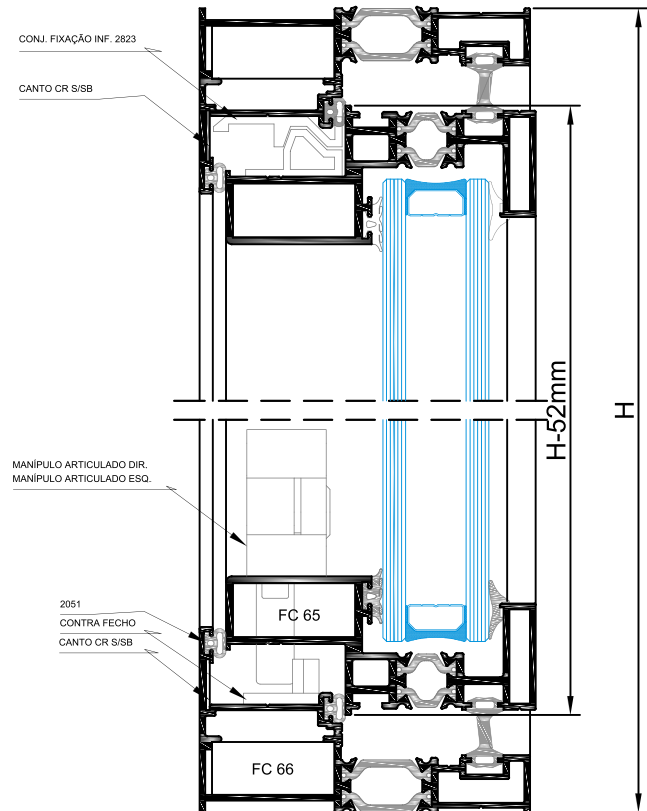
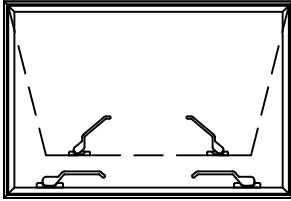

JANELAS PROJETANTES
COM OS PERFIS FC 65, FC 66 e FC 69

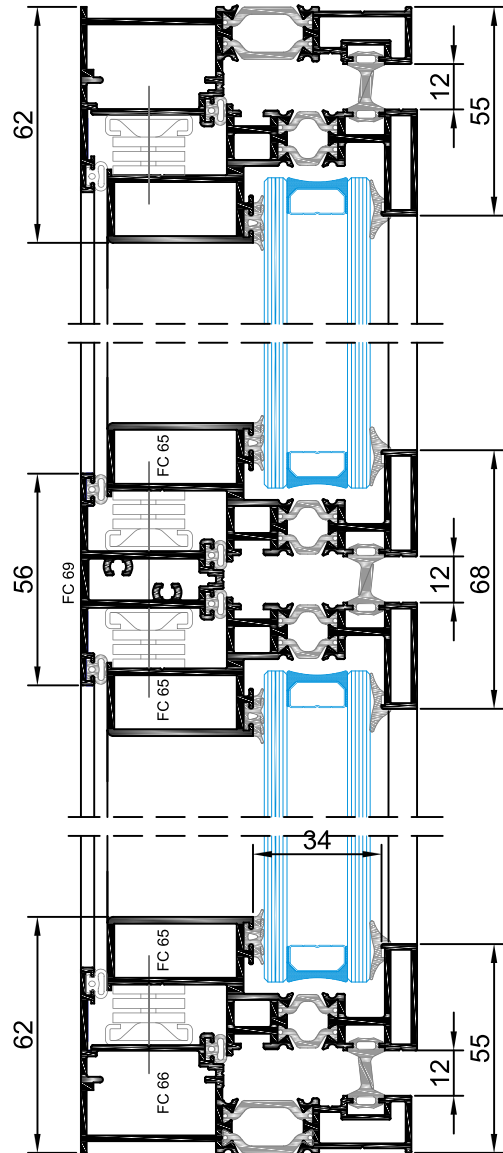
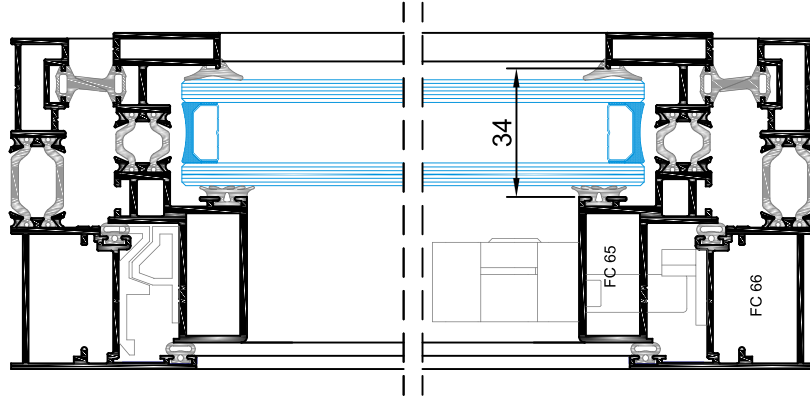
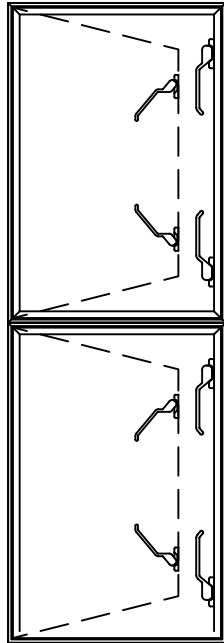

FACHADA DEC: PORMENORES 1 E 2

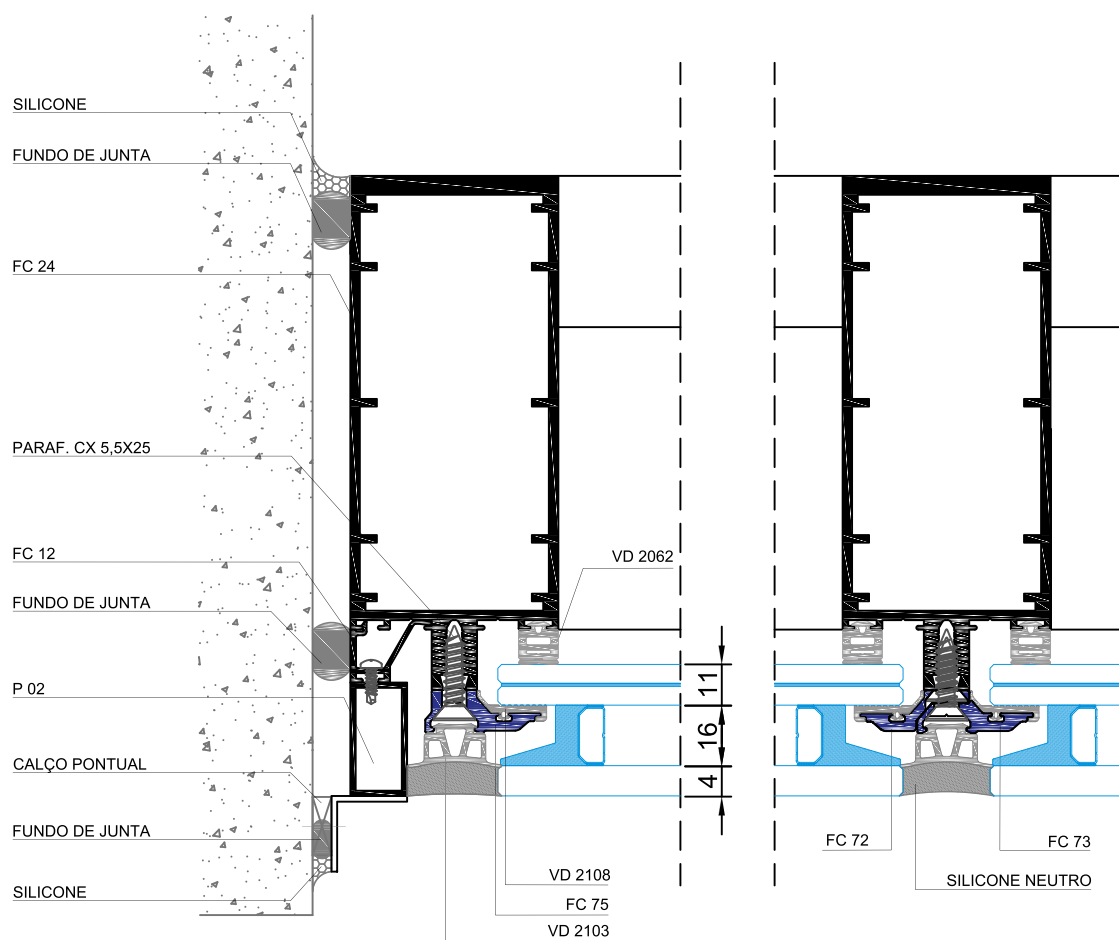
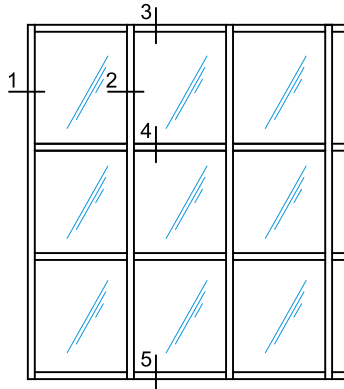

1

2

FACHADA DEC: PORMENORES 1 E 2

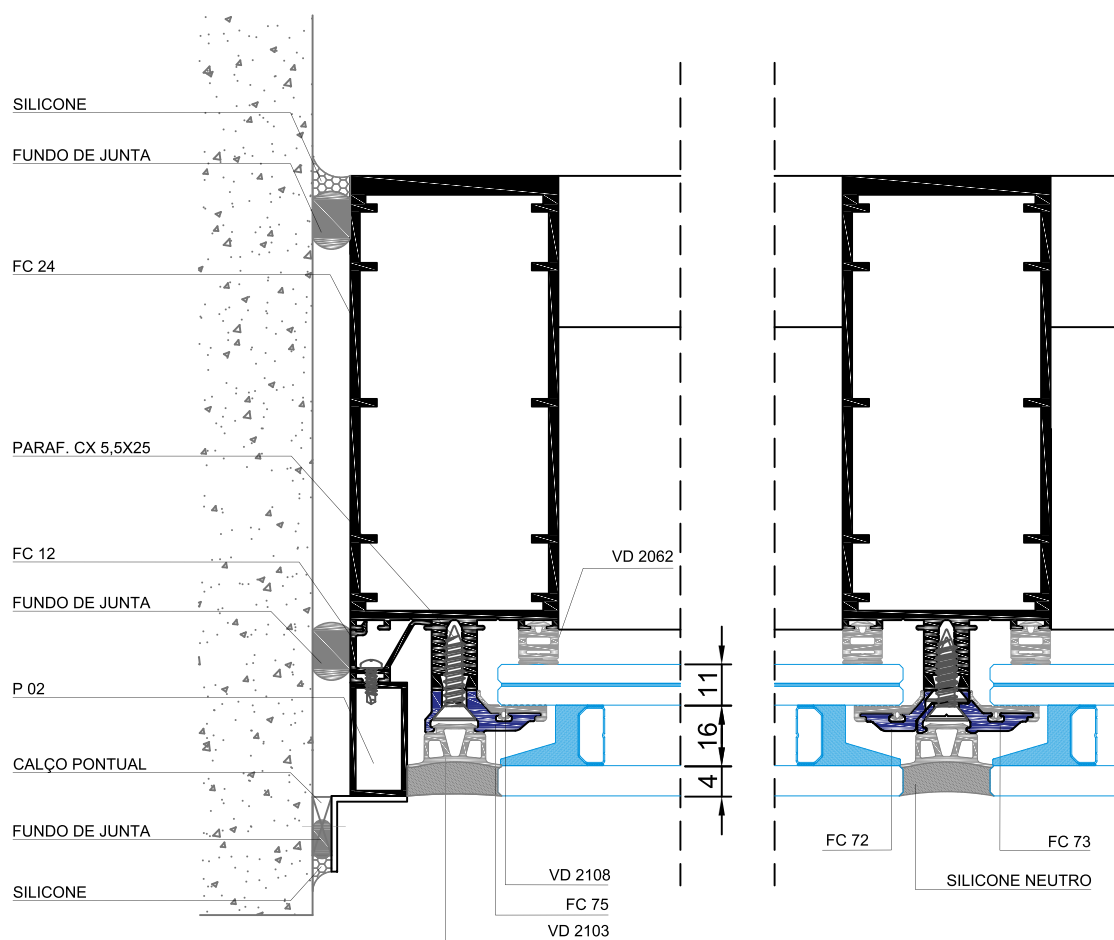
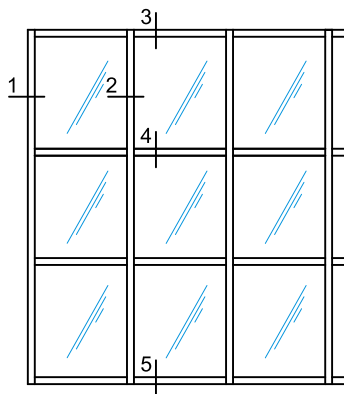

1

2

FACHADA DEC: PORMENORES 3 E 4

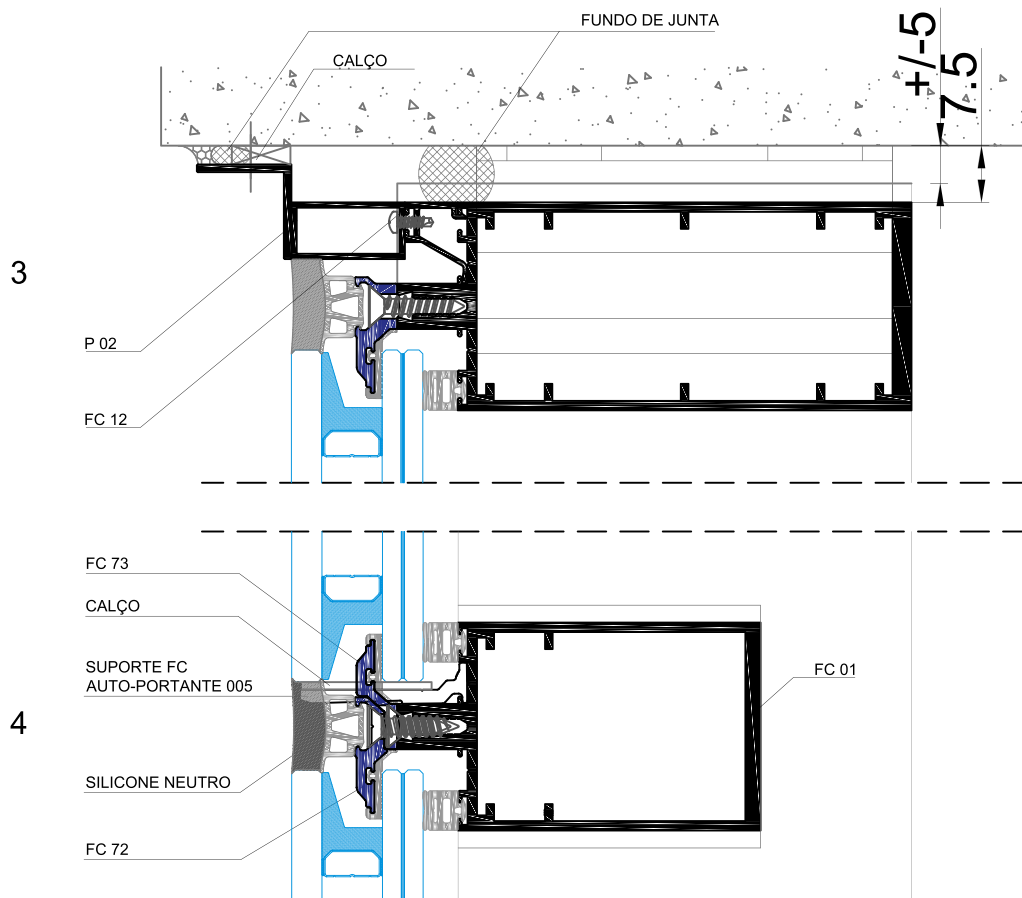
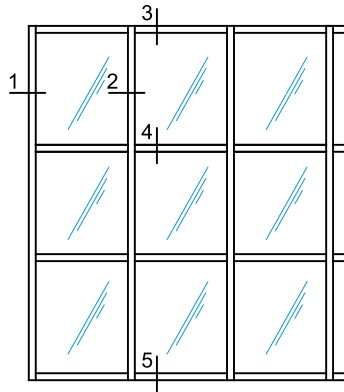

FACHADA DEC: PORMENOR 5

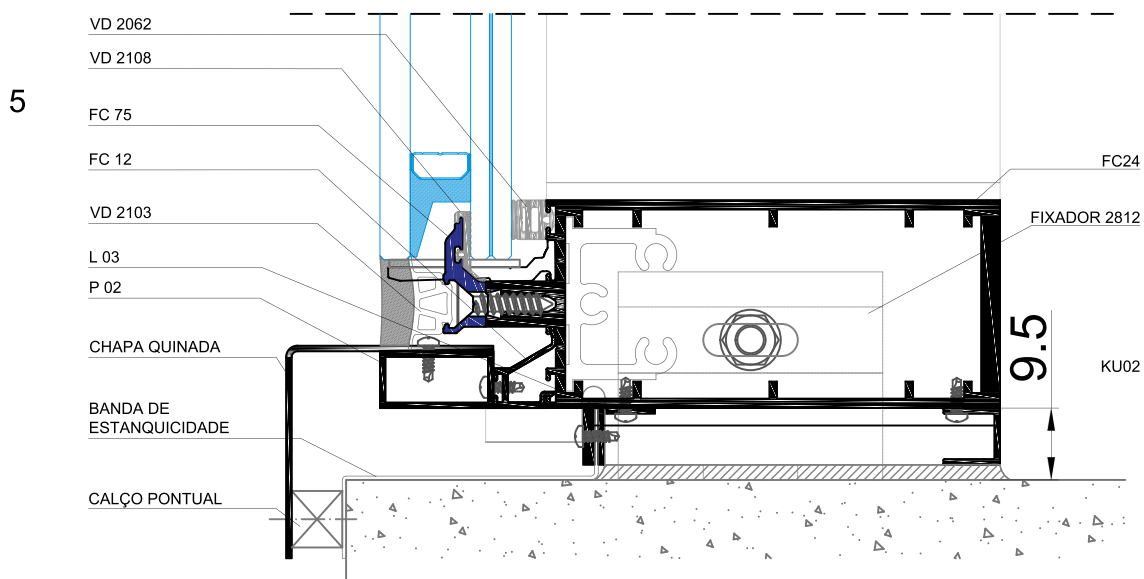
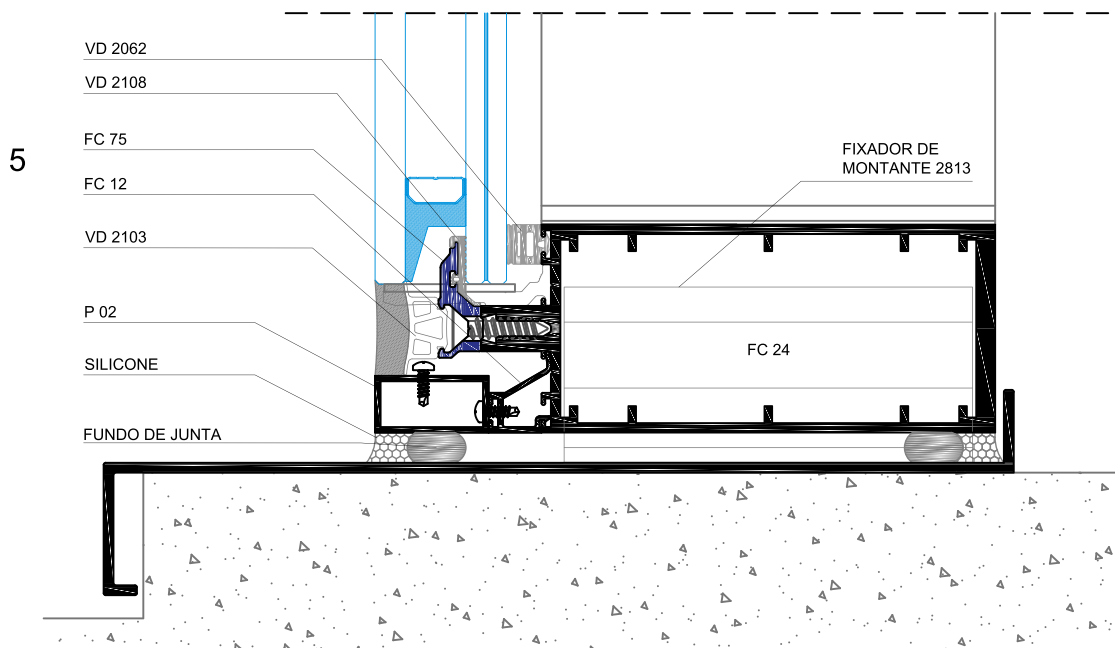
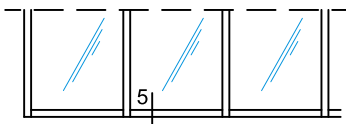

FACHADA DEC: CANTO 90° EM VIDRO

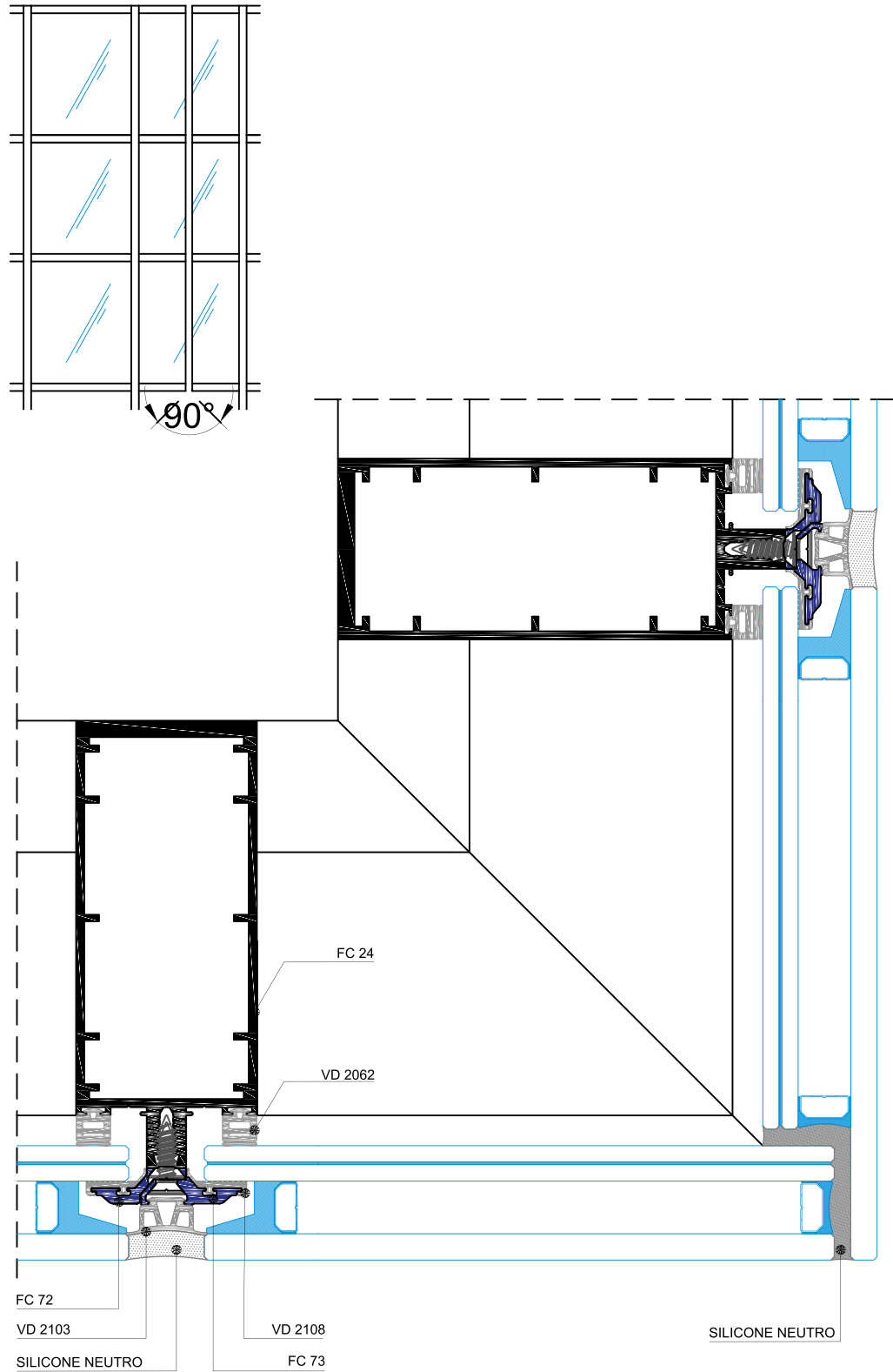

FACHADA DEC: CANTO 90° EM CHAPA

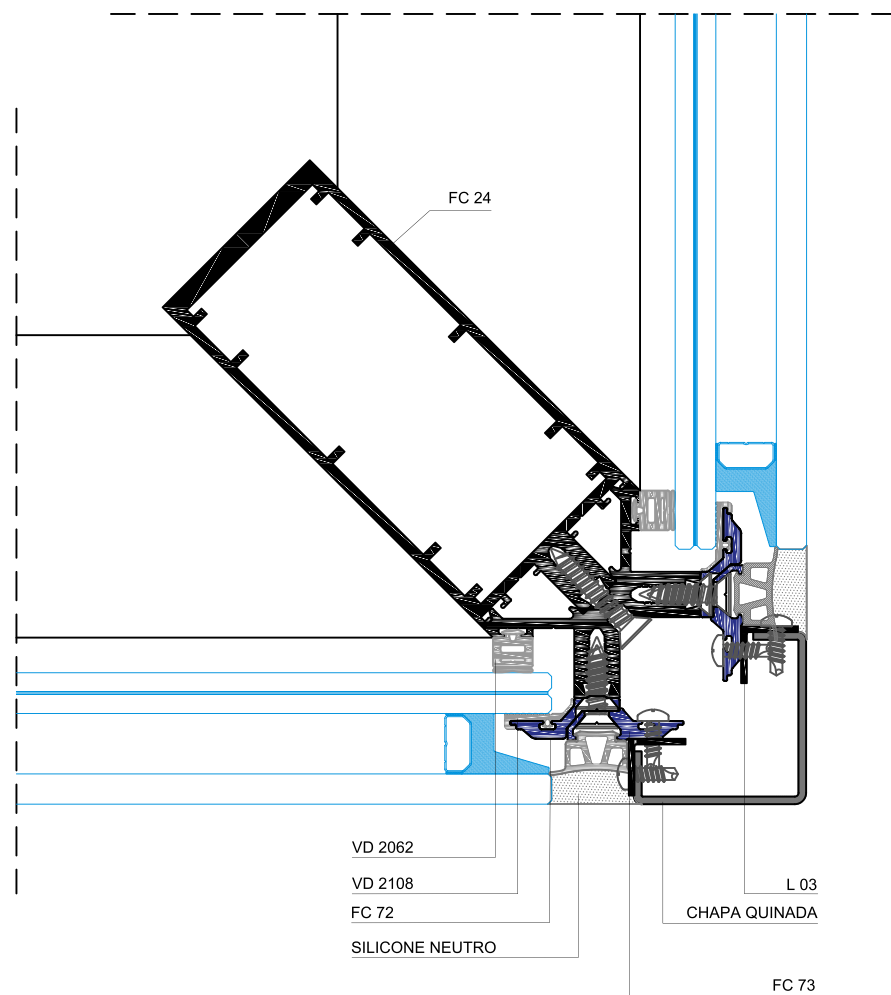
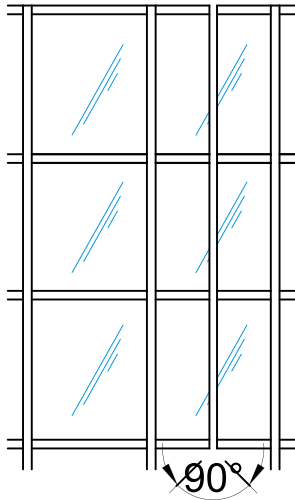



NORTALU[®]

📍 Rua Dr. José Bragança Tavares, 78 Fr. A
4580-593 Paredes(Mouriz)

☎ 255 781 548/49

☎ 92 705 80 65

✉ nortalu@nortalu.com



www.nortalu.pt



www.nortalu.com



www.nortalu.fr